



Measurements of neutrino-nucleus scattering

Callum
Wilkinson



u^b

^b
**UNIVERSITÄT
BERN**

AEC
ALBERT EINSTEIN CENTER
FOR FUNDAMENTAL PHYSICS

Cross section basics

All oscillation experiments live in the 0.1-10 GeV transition region.

Multiple models required with different physical assumptions.

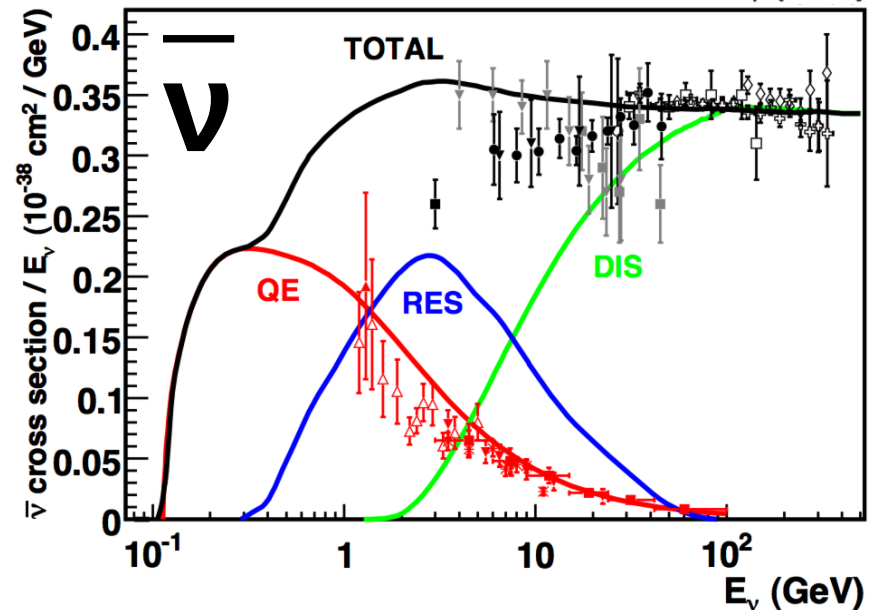
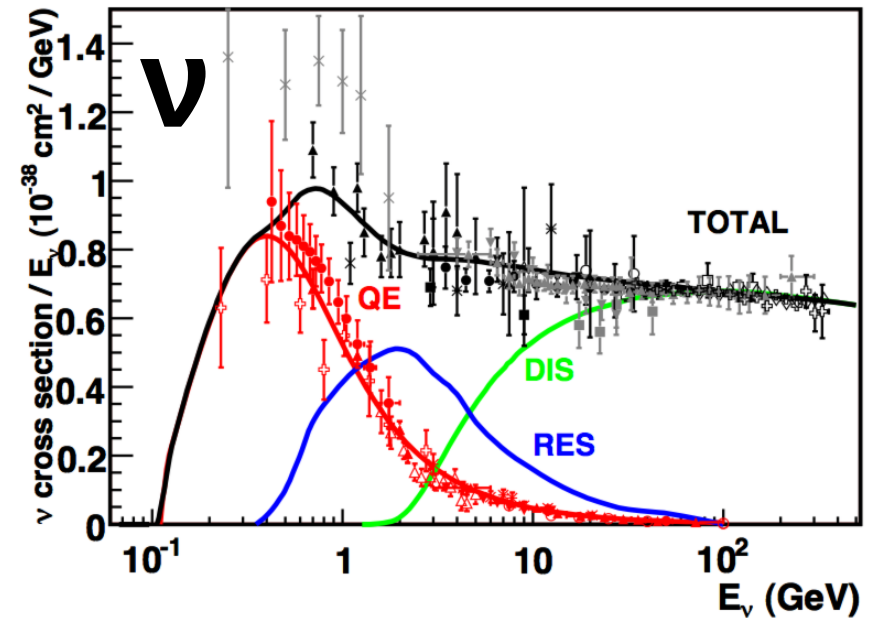
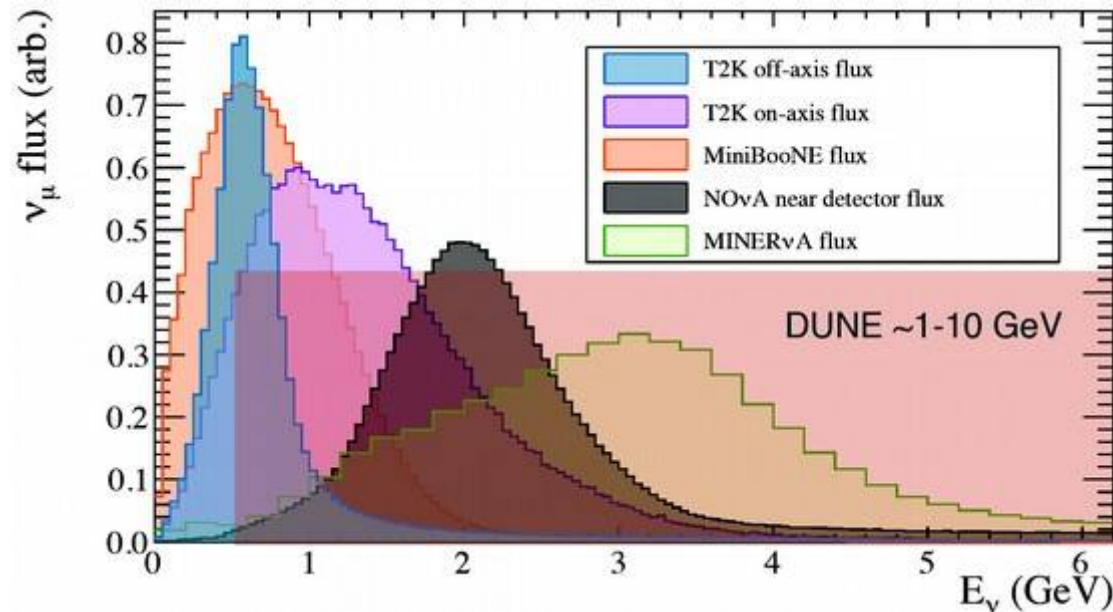

Importance for OA

$$R(\vec{x}) = \underbrace{\Phi(E_\nu)}_{\text{Near}} \times \underbrace{\sigma(E_\nu, \vec{x})}_{\text{Near}} \times \underbrace{\epsilon(\vec{x})}_{\text{Near}} \times \underbrace{P(\nu_A \rightarrow \nu_B)}_{\text{Far}}$$

- **Event rate; Neutrino flux; Cross section; Detector smearing; Oscillation probability.**
- Require model to relate observables \vec{x} and E_ν
- Near/far ratios don't fully cancel systematics:
 - Dramatic change in E_ν distribution
 - Different ND/FD design, acceptance

Free nucleon response

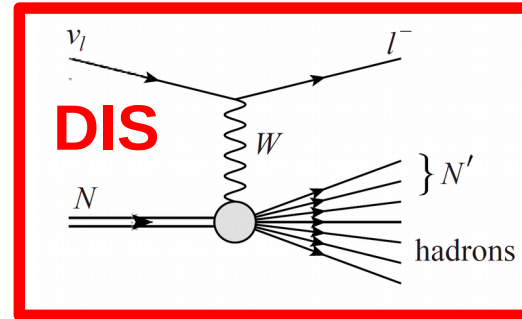
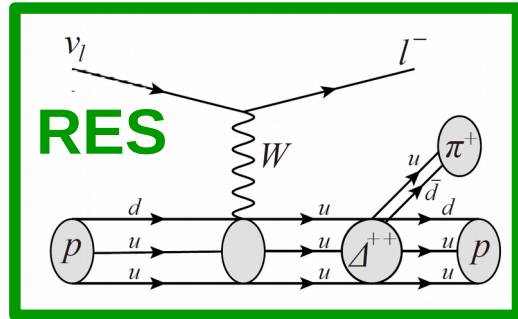
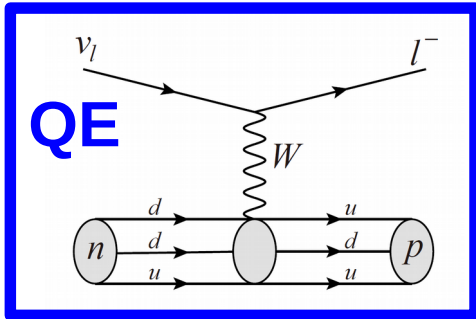
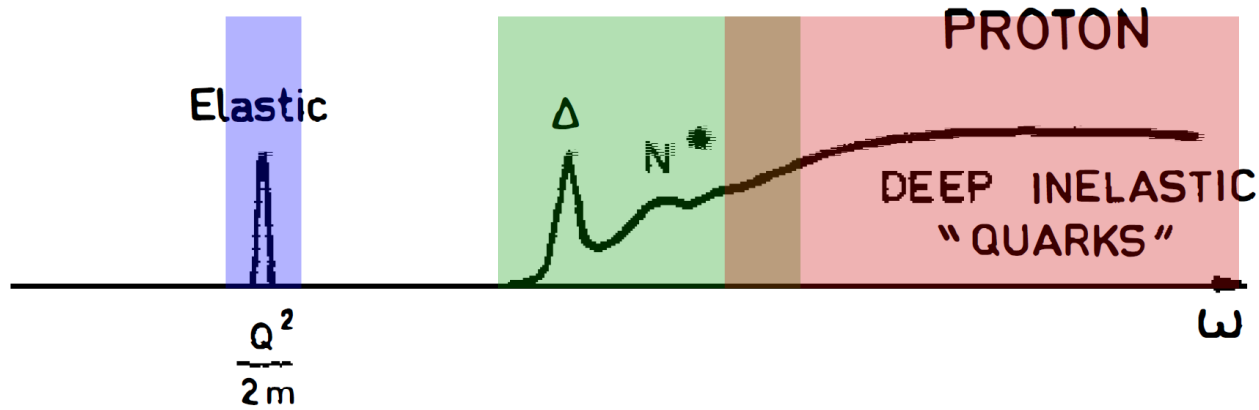

Nuclear response

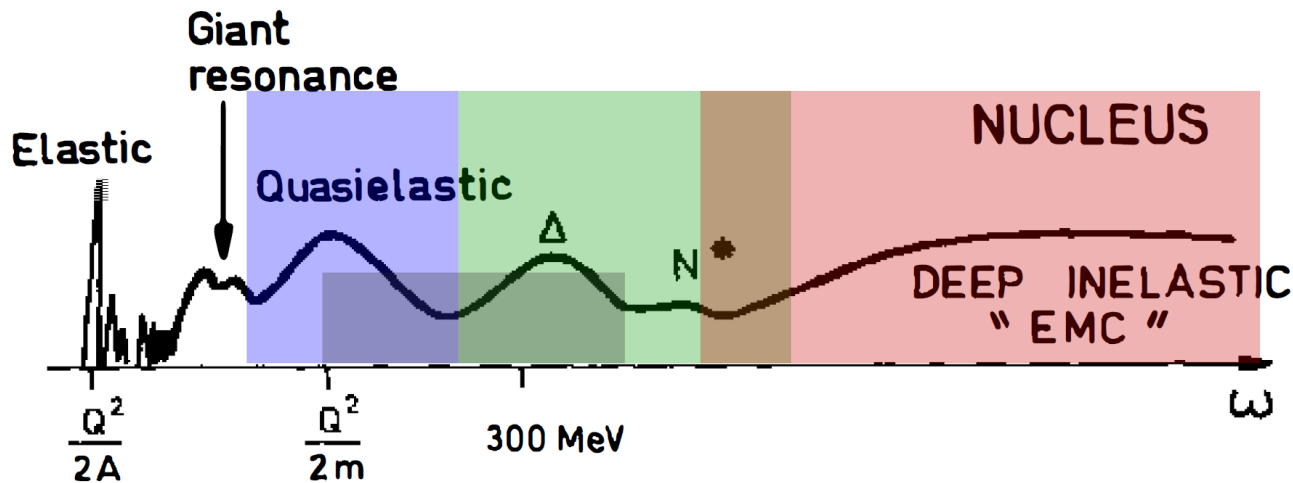
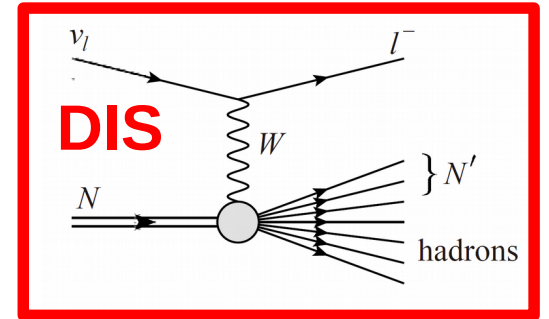
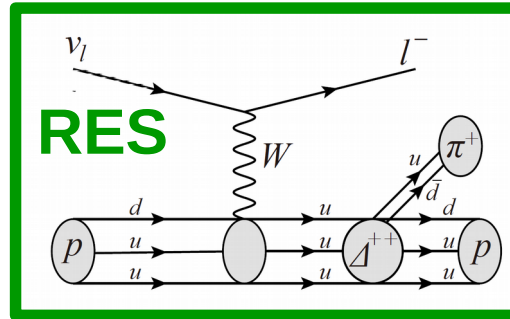
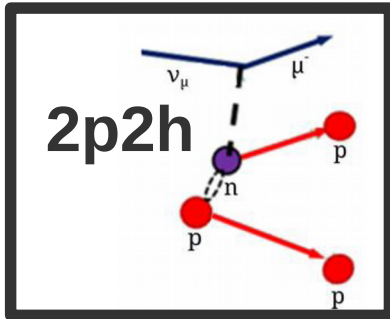
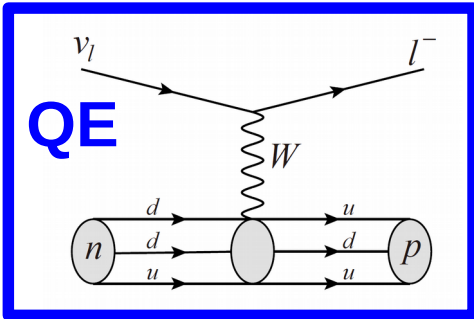
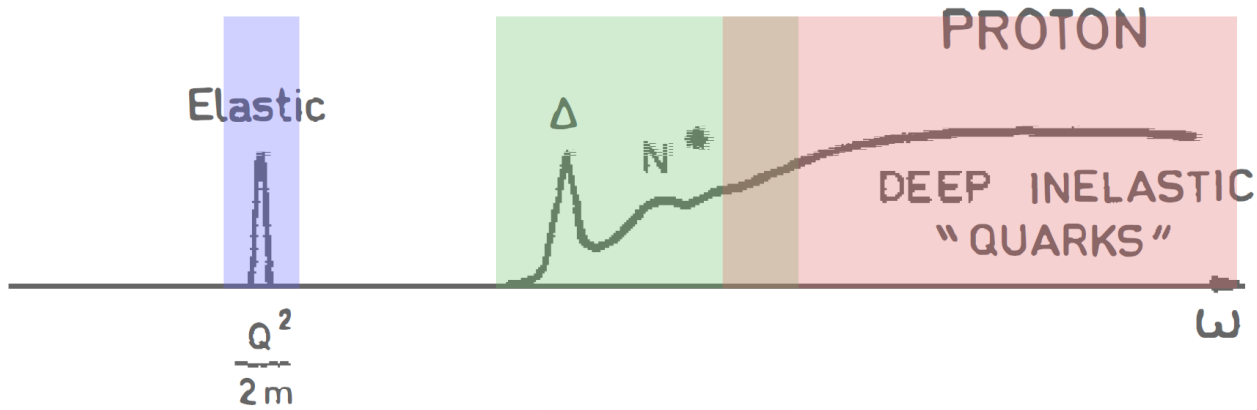

Interactions with more than one nucleon contribute

Nuclear response

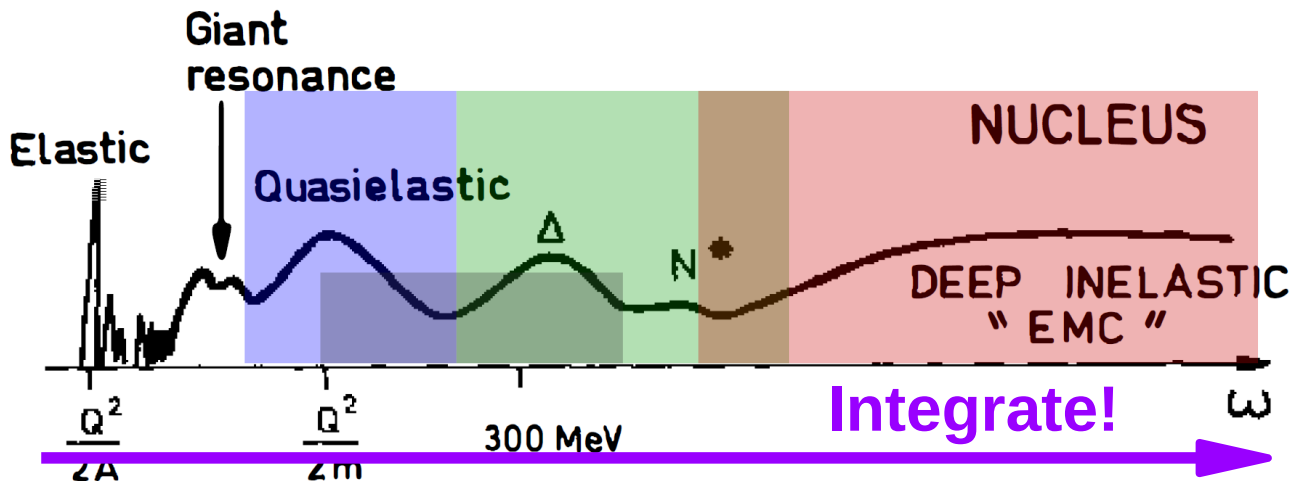
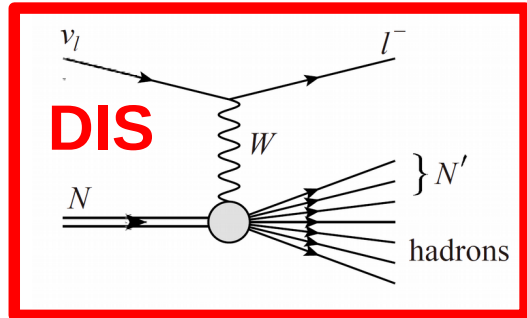
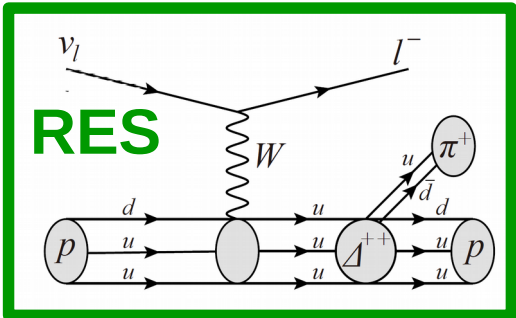
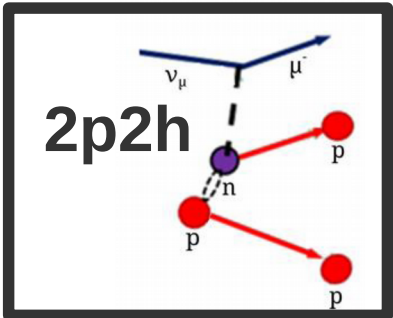
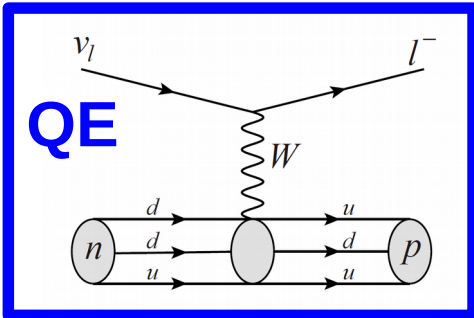
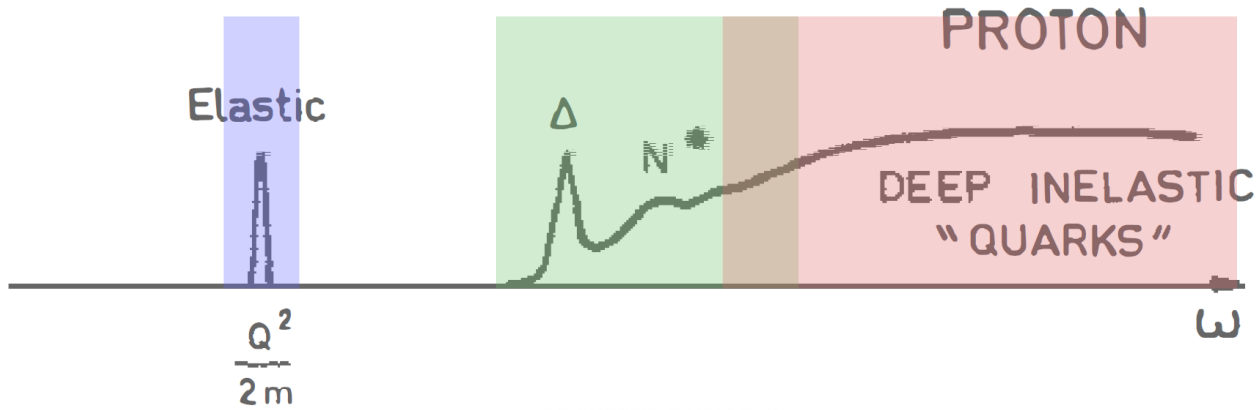

Can't reconstruct ω , so no way to avoid poorly modelled regions!

The plot thickens

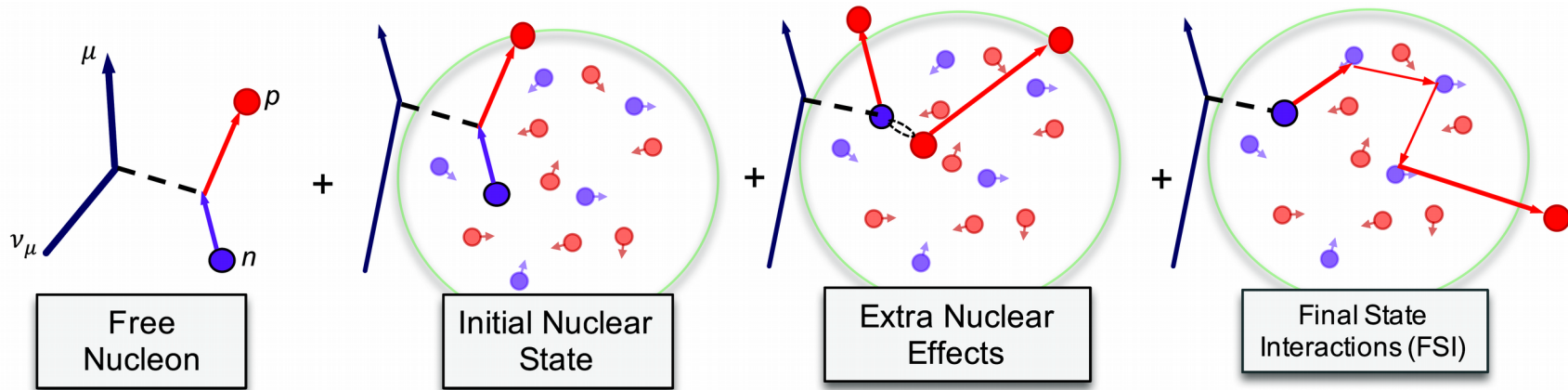

$$R(\vec{x}) = \Phi(E_\nu) \times \sigma(E_\nu, \vec{x}) \times \epsilon(\vec{x}) \times P(\nu_A \rightarrow \nu_B)$$

Final state particle content does not isolate initial interaction type!

What do we actually measure?

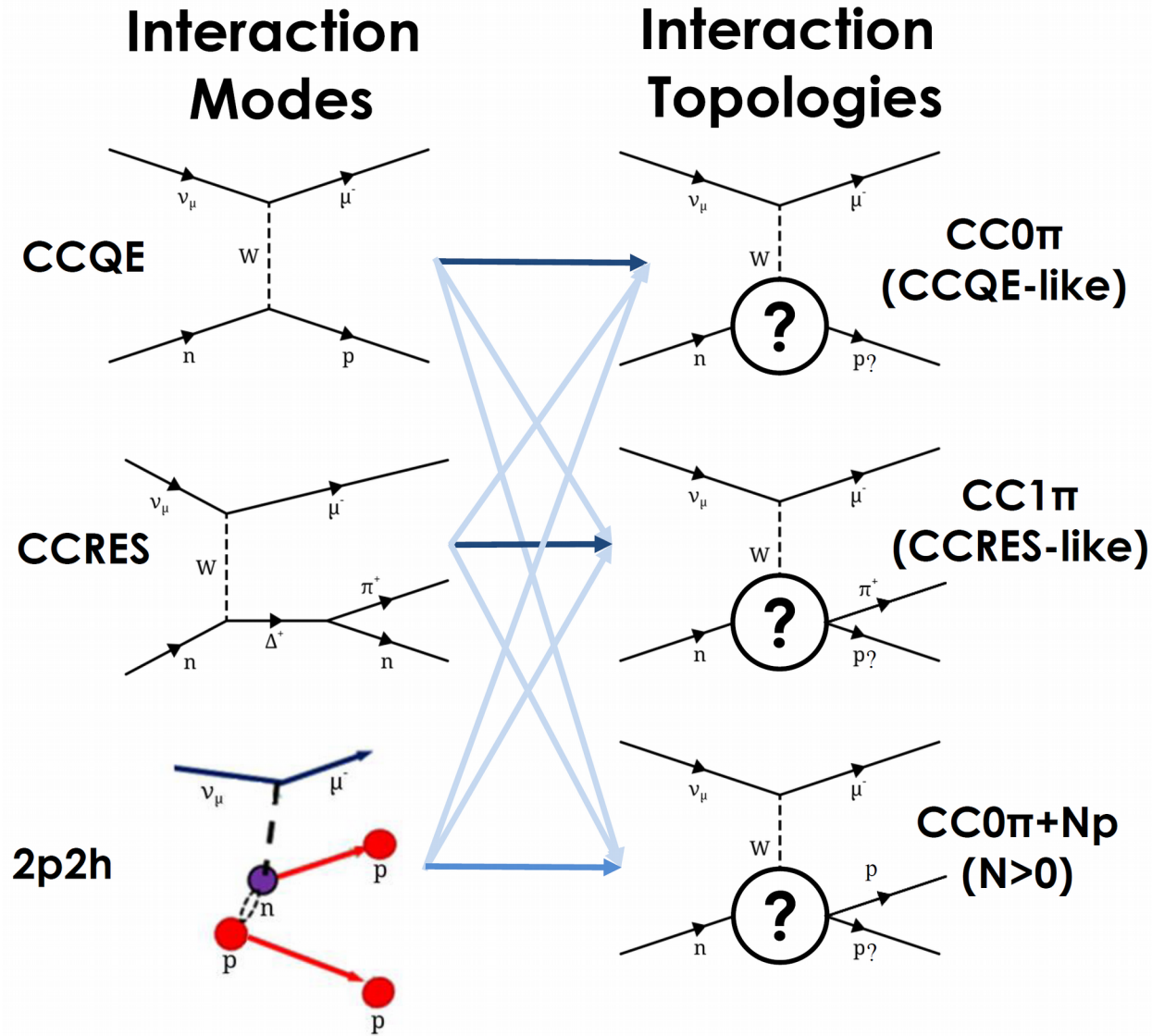

Many modes contribute to any measurement

Integrated over broad ω region

Difficult to tune theory models!

Focus on CC0 π

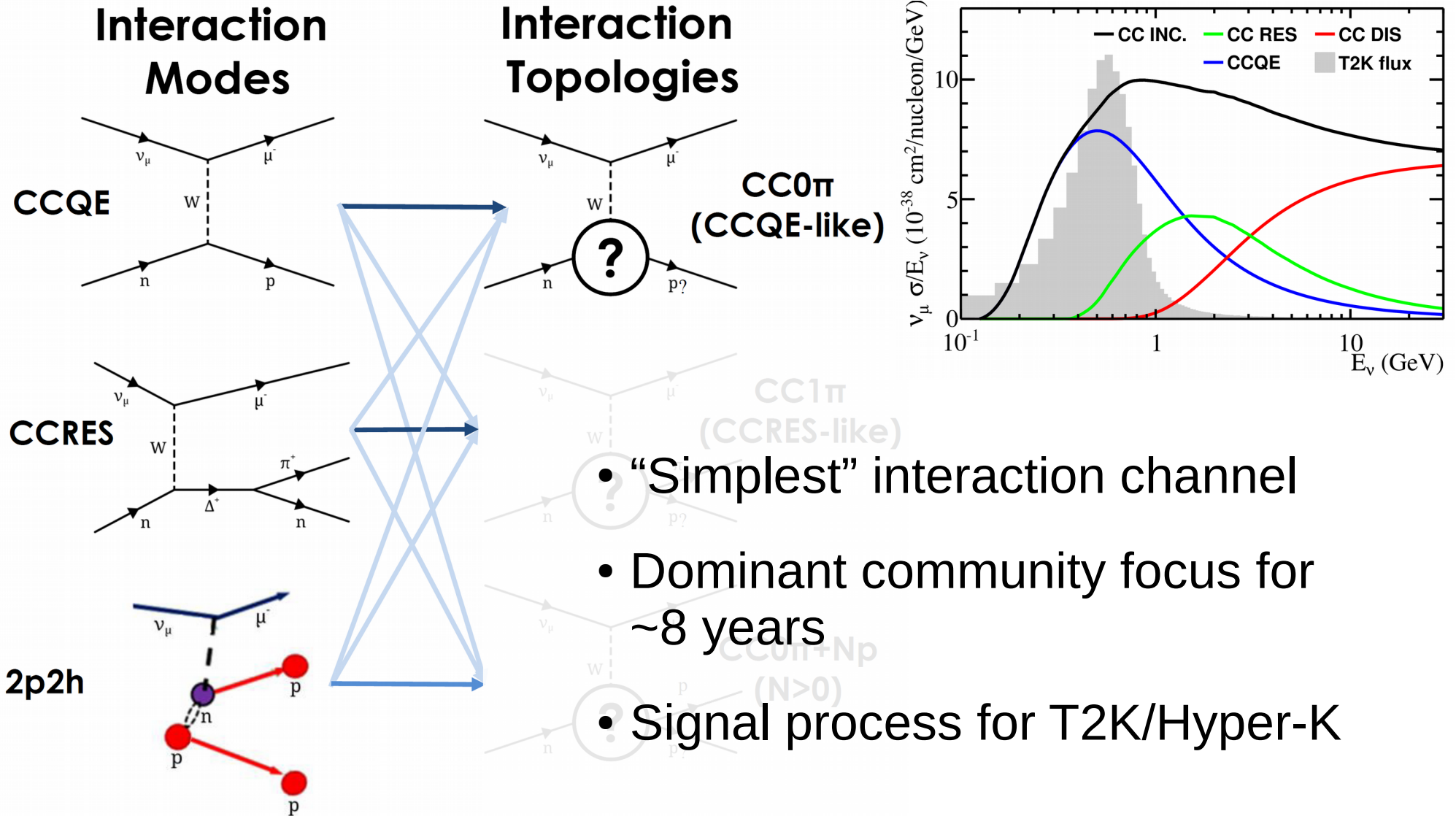

$$\text{CC0}\pi = 1\text{p1h} + 2\text{p2h} + 1\pi(+\text{abs}) + \dots$$

CC0 π model development

- New theoretical models to describe CC0 π process
 - Nuclear model
 - N-N correlations
 - Multi-nucleon final states
- Improves agreement with ν -A and e-A data!

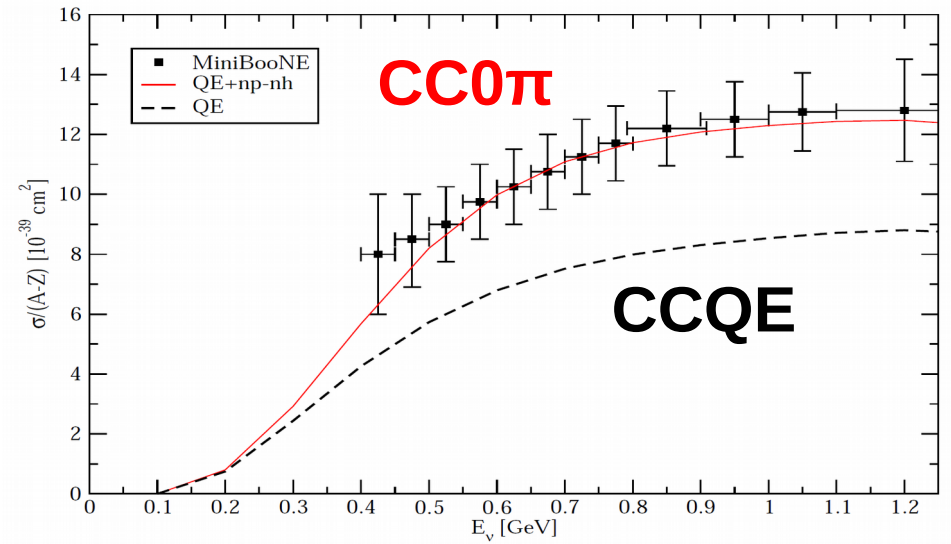

PRC 80 065501 (2009)

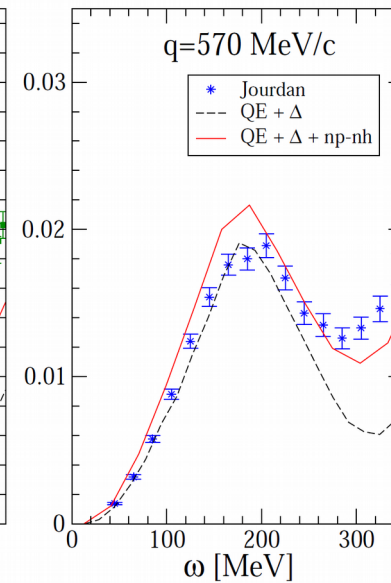
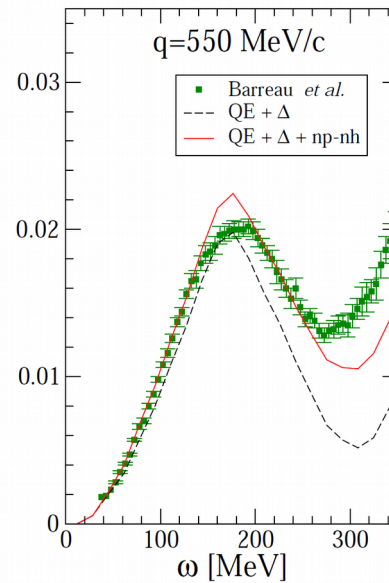
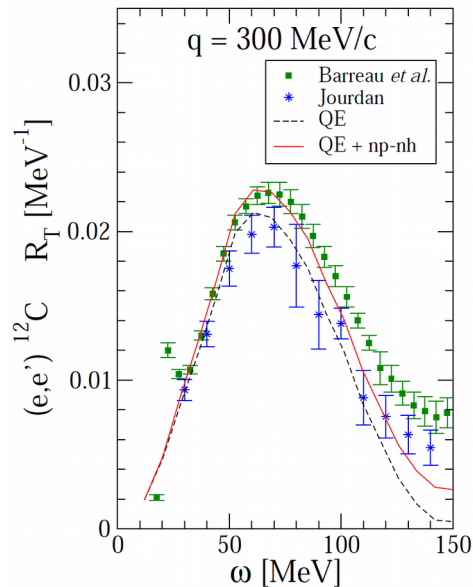

New CC0 π measurements (T2K)

- Spate of new data: T2K ν_{μ} - C_8H_8 CC0 π shown
- New models agree *qualitatively* with new data

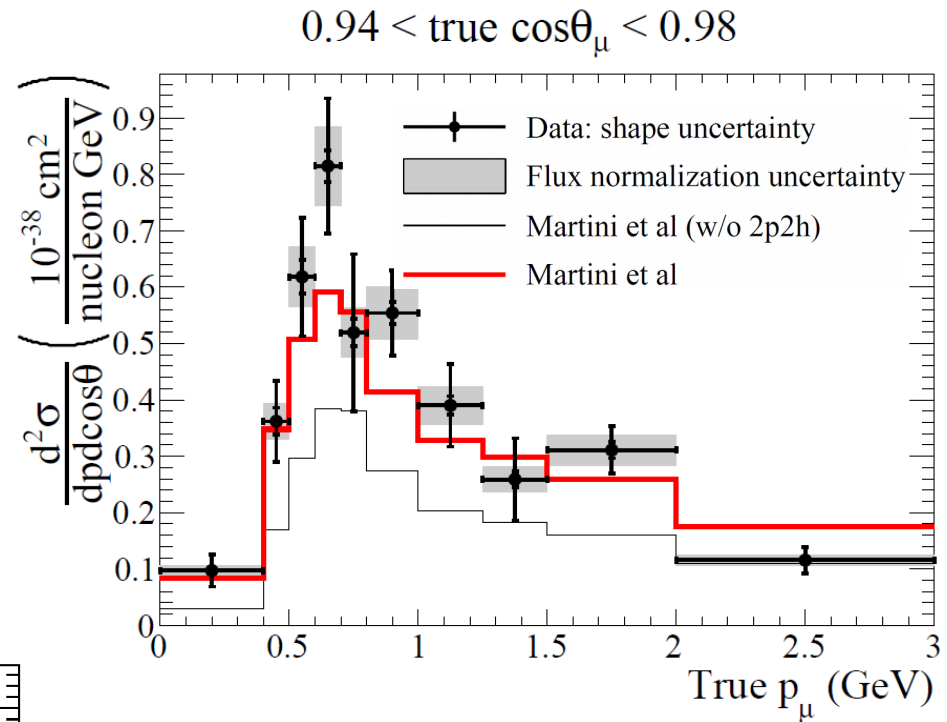
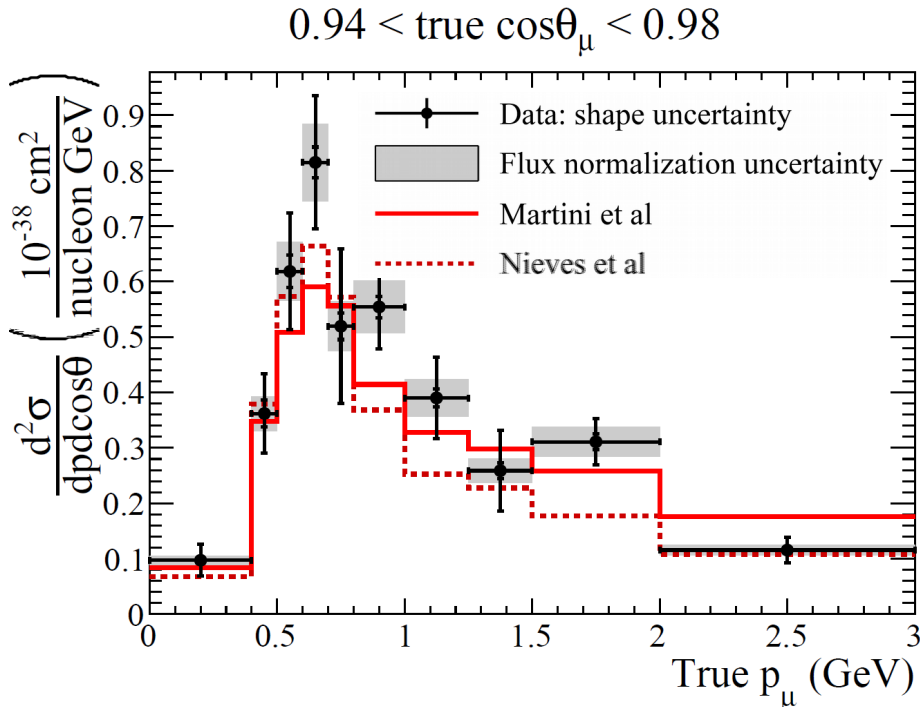

- Alternative models look very similar in this space, but differ in E_{ν}, ω, q_3
- p_{μ}, θ_{μ} not very sensitive to model differences

New CC0 π measurements (MINERvA)

- Similar effort from MINERvA to make measurements using only the leptonic variables. $\bar{\nu}_\mu$ -C₈H₈ CC0 π here
- Generally not very sensitive to nuclear effects
- Important as many old datasets suffer from subtle model dependence issues \rightarrow ongoing work to handle these

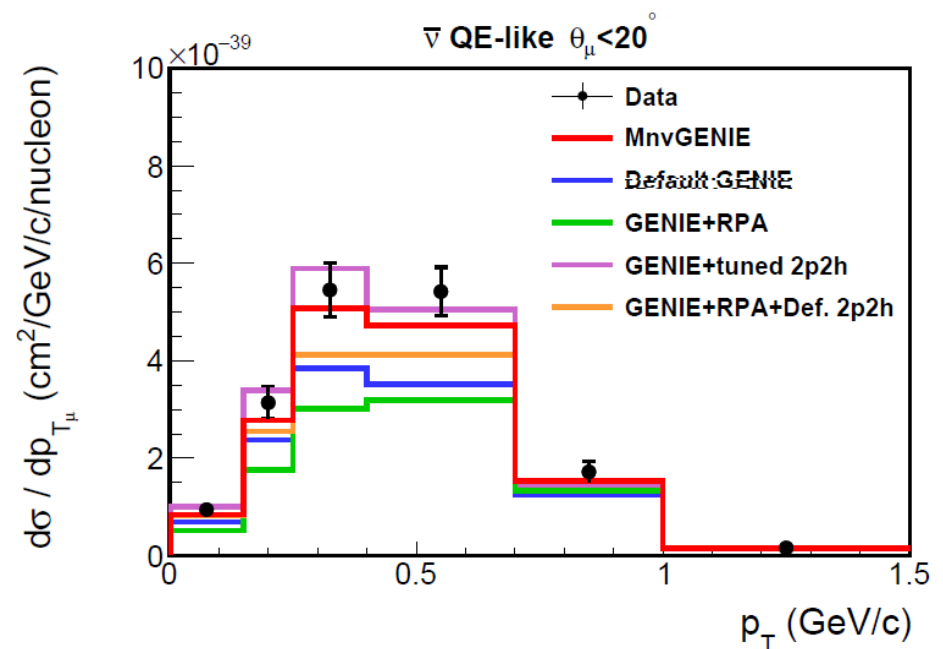
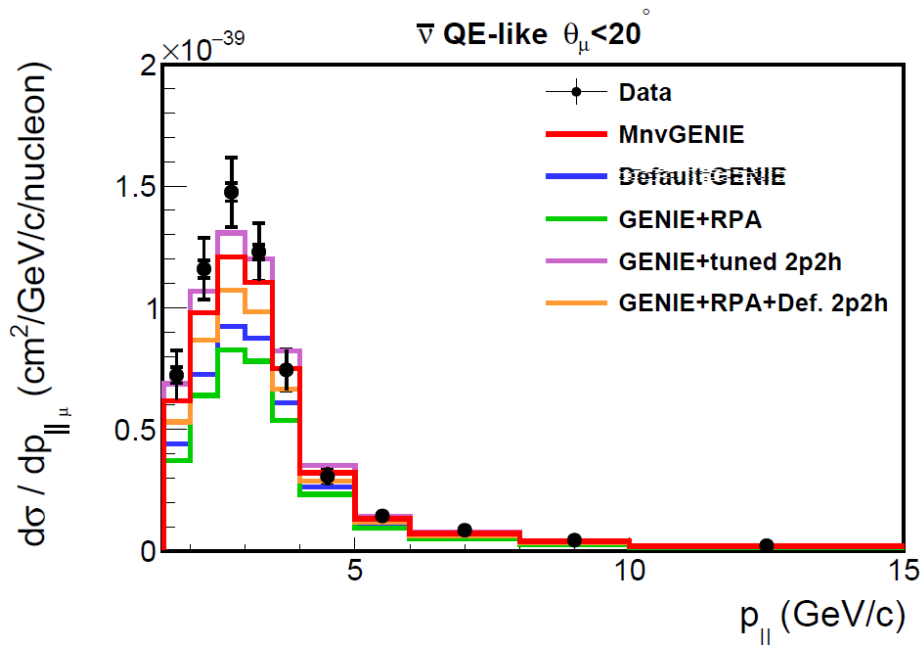

New CC0 π variables

- Experimental focus on new variables to probe models
- T2K and MINERvA CC0 π +1 p : transverse imbalances between μ^- and proton
- Break degeneracy between 2p2h, FSI, nuclear model

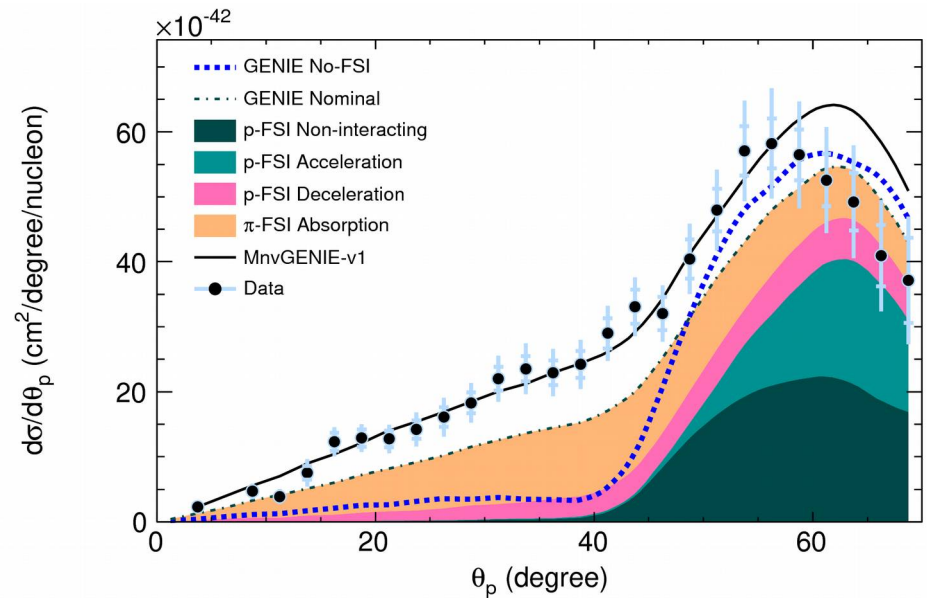
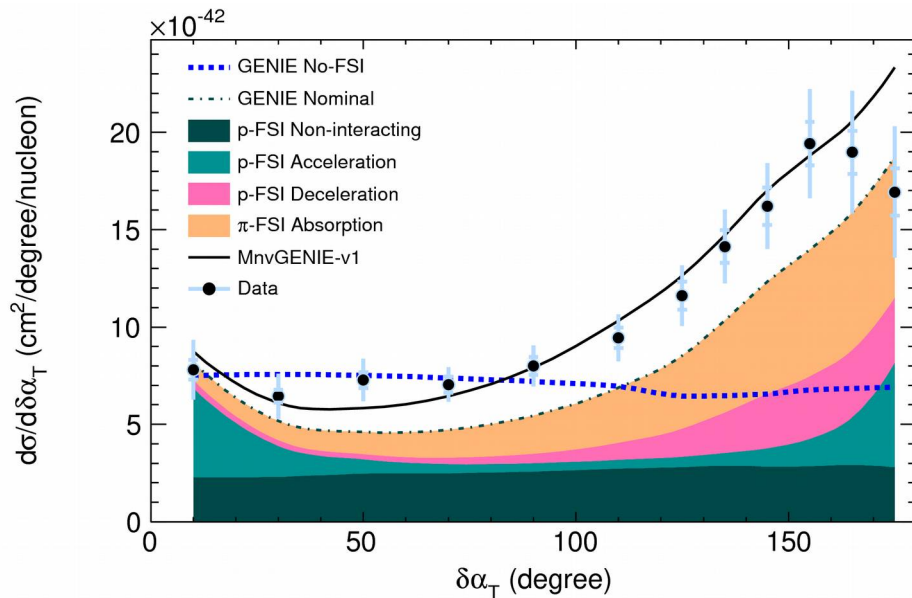
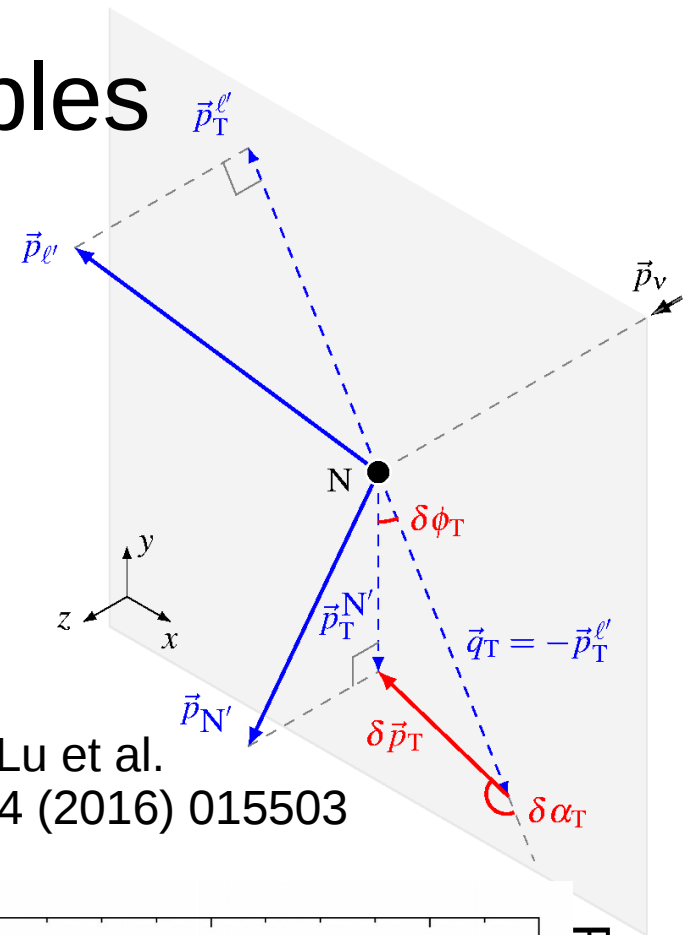

PRL121 (2018) 022504

New CC0 π variables

- New data from T2K and MINERvA motivate new theoretical work
- Current models simply cannot cope with such stringent tests
- Long delay between experiment and useful theory inputs for OA

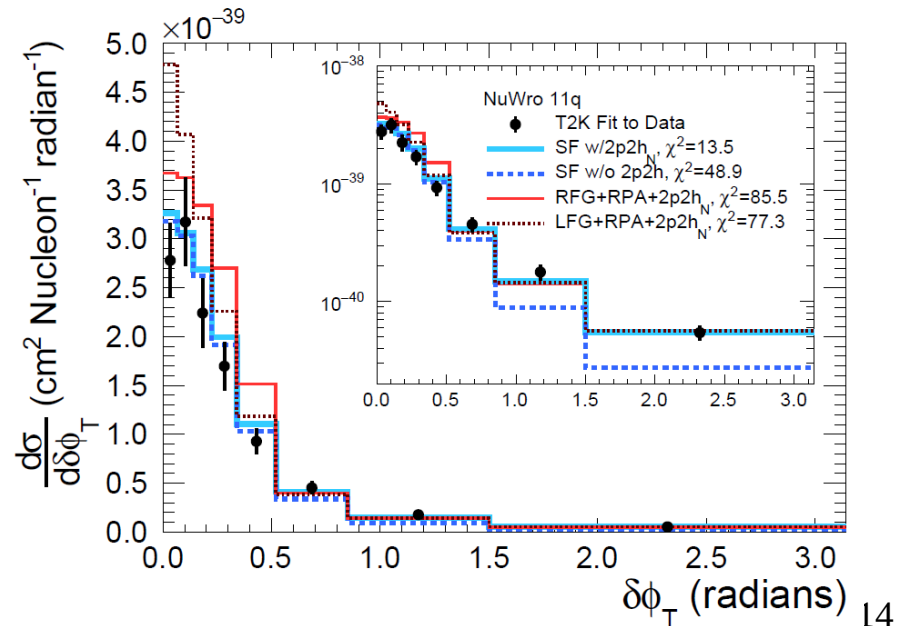
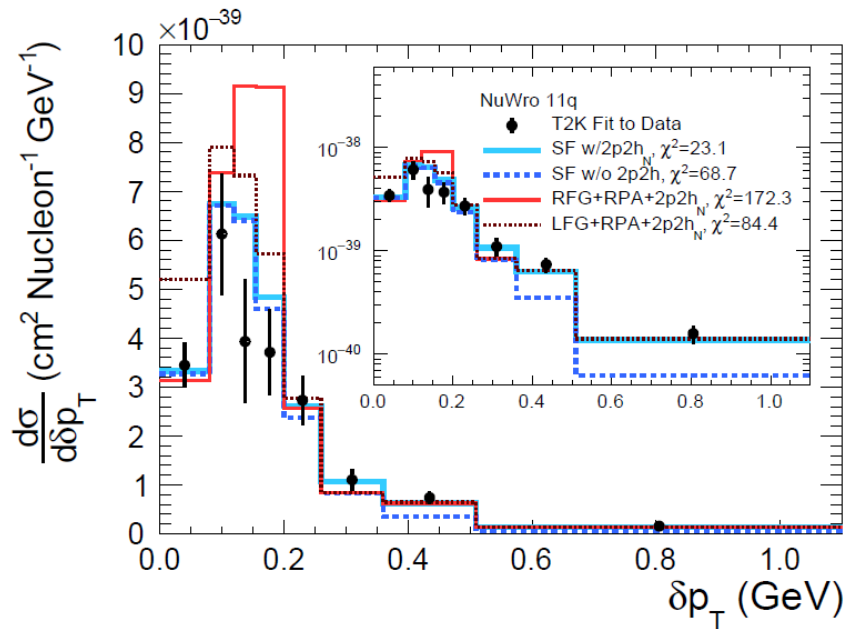
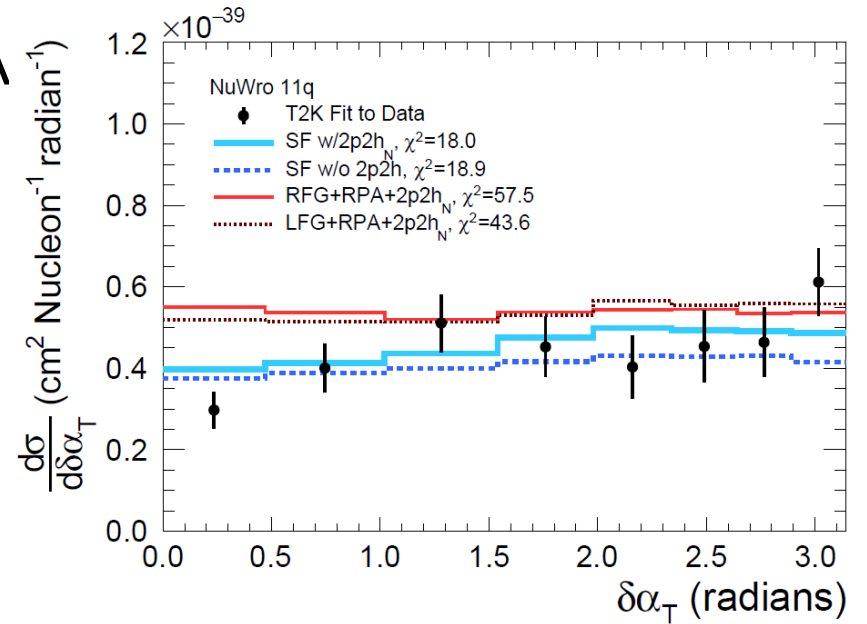



MINERvA CC-inclusive

e-A

ν -A

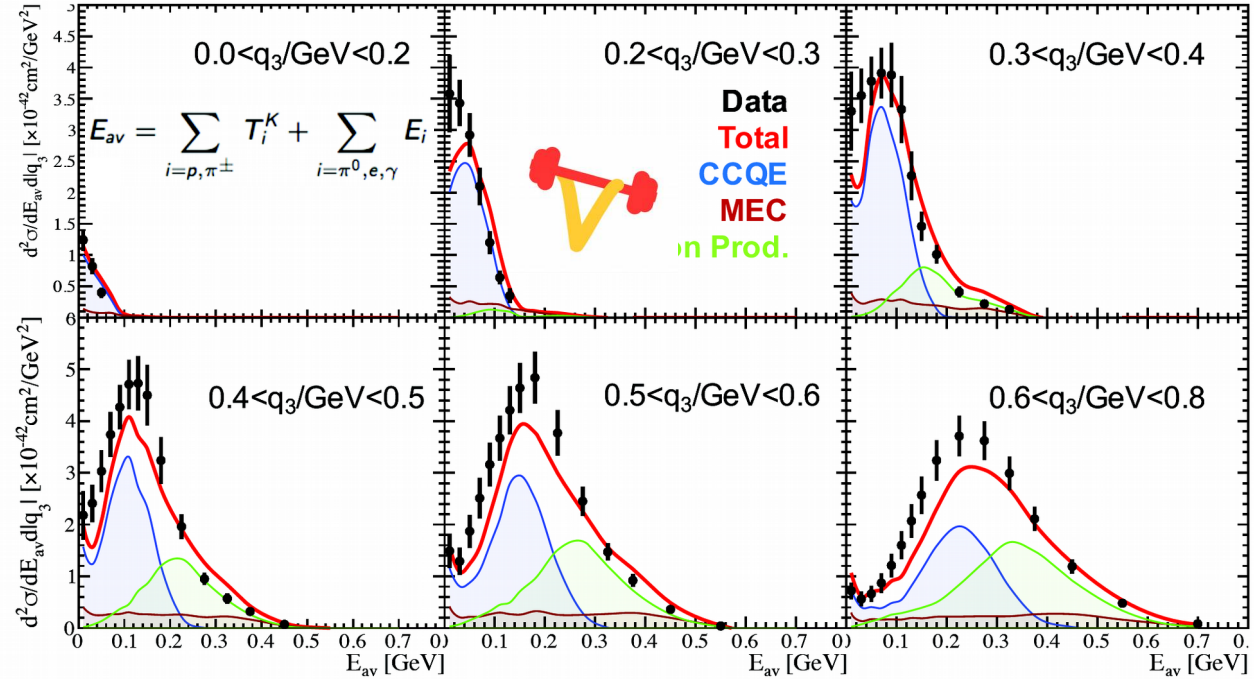
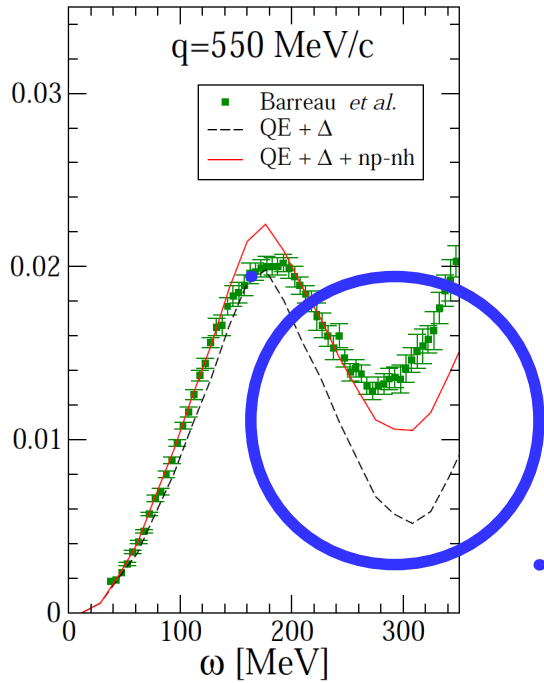

PRL 116 (2016) 071802

- Effort to measure low momentum transfer events in *interaction level* kinematics
- Aim to isolate “dip” region between QE and Delta
- Clear data excess in this area, but hard to isolate cause because the measurements aren’t as clean as e-A

Single pion production

Interaction Modes

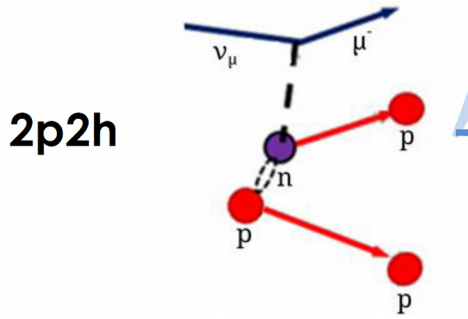
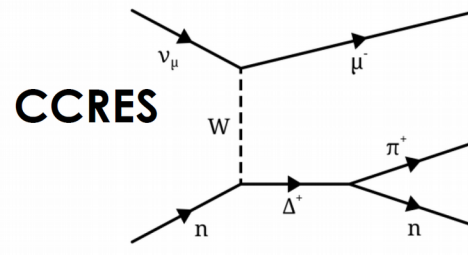
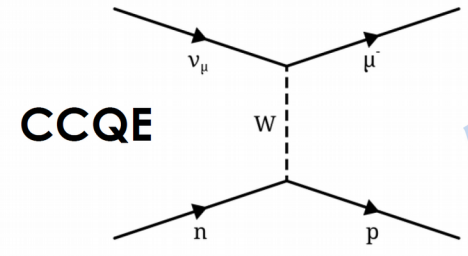

Interaction Topologies

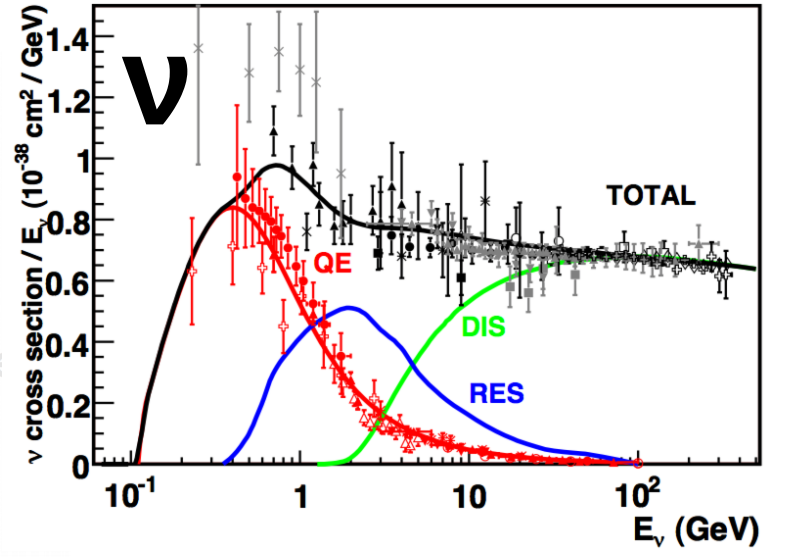
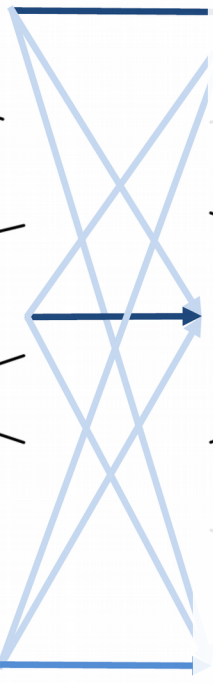
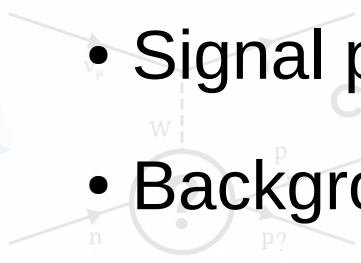
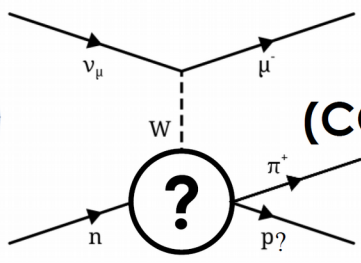
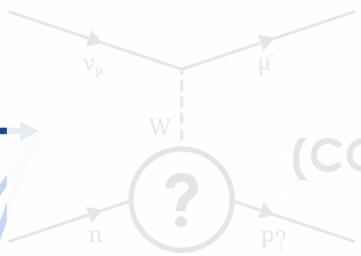

- Signal process for NOvA/DUNE
- Background for T2K/Hyper-K

Single pion production

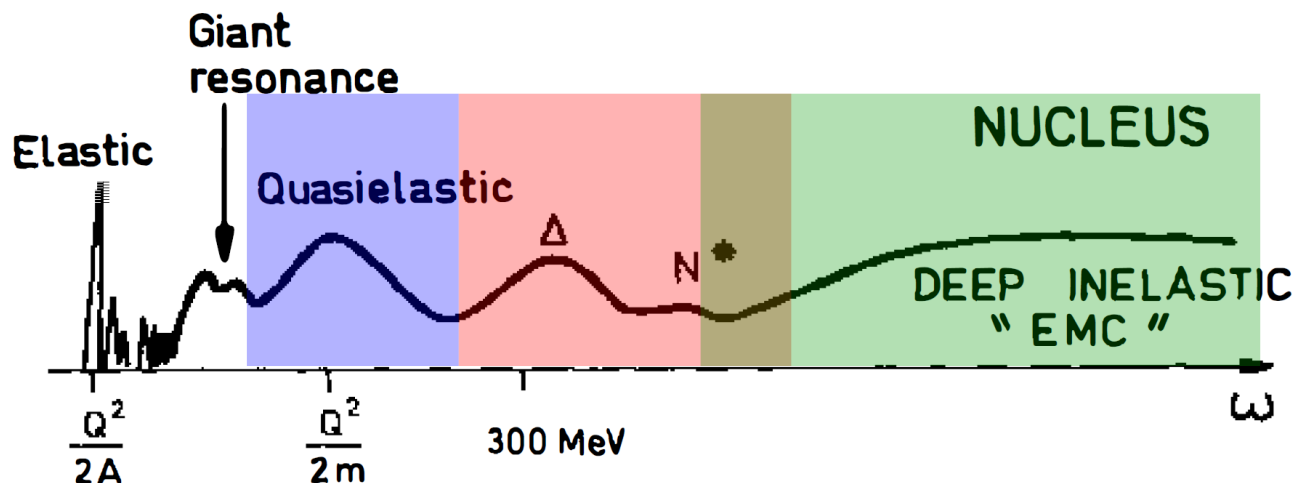

Pion production from broader ω space than $CC0\pi$, spans very different theory models:

- Coherent
- Resonant
- DIS

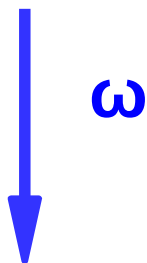

Much harder to measure experimentally (higher multiplicities)

Single pion production

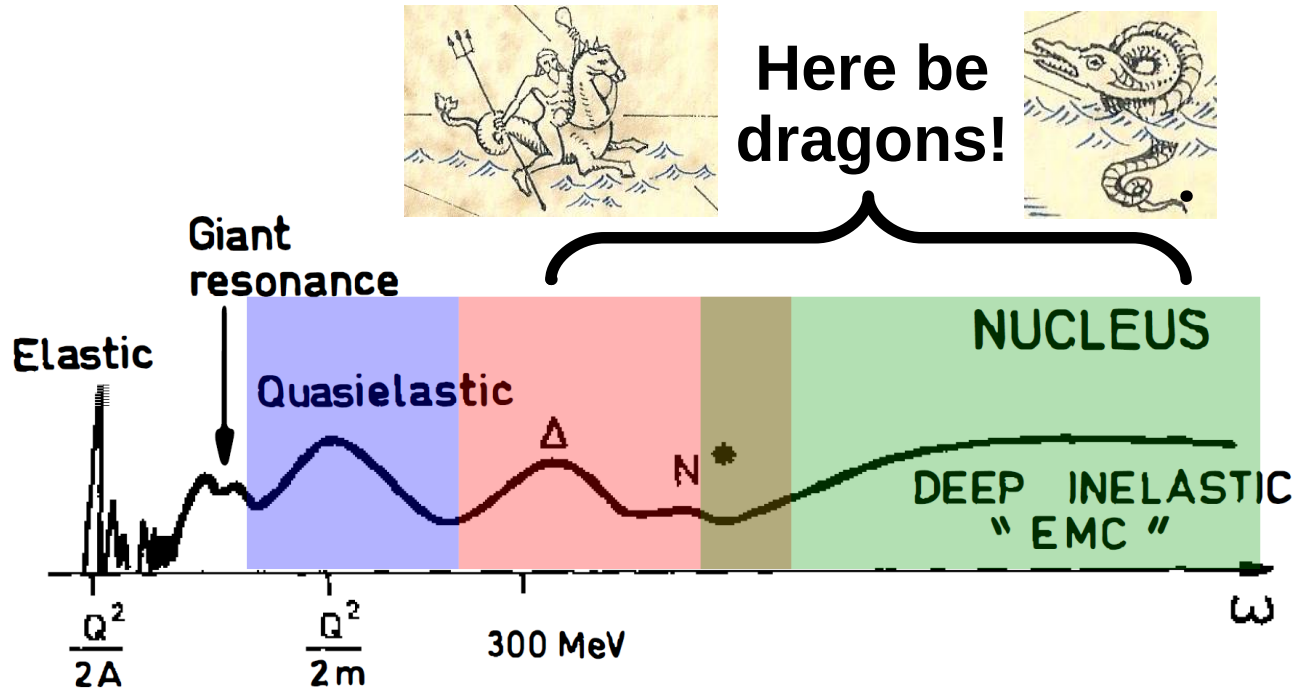

Here be dragons!



Pion production from broader ω space than $CC0\pi$, spans very different theory models:

- Coherent
- Resonant
- DIS



Much harder to measure experimentally (higher multiplicities)



ν -A data-MC disagreement

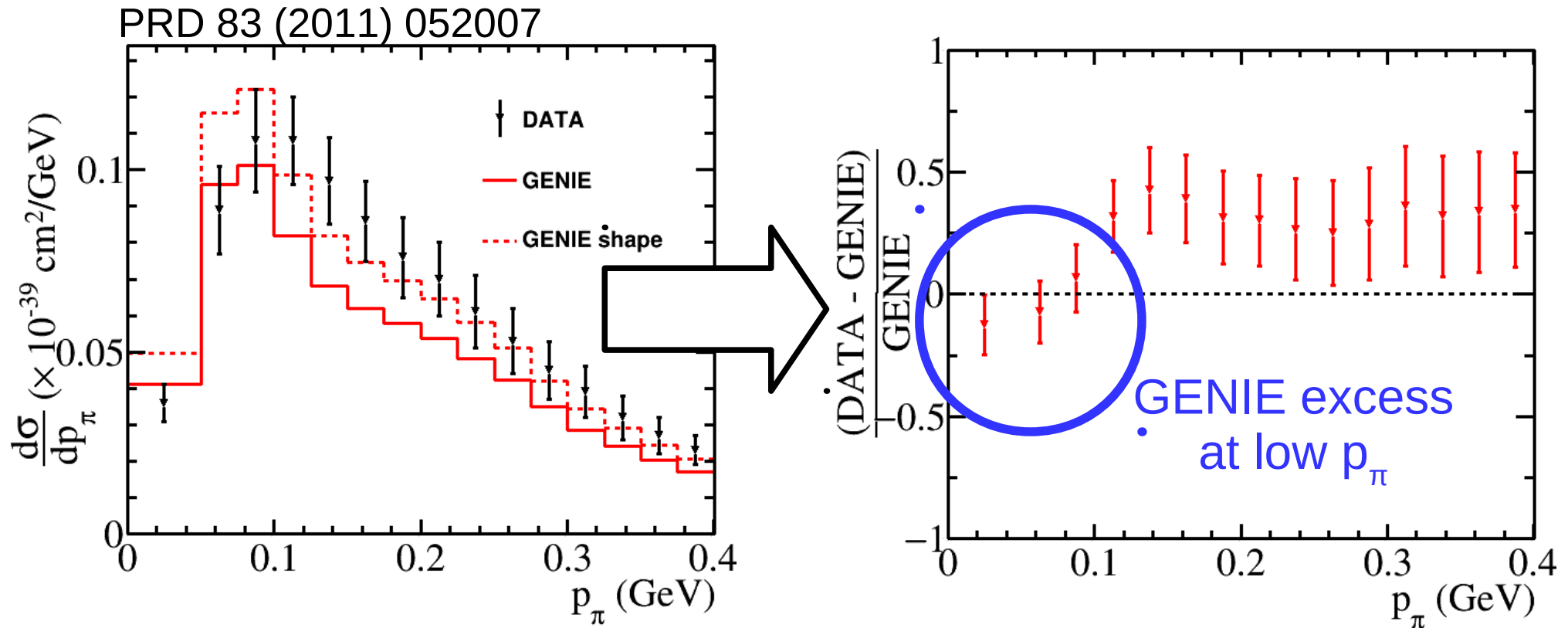

- Many ~ 10 datasets in a variety of different kinematic variables. All measurements flux-averaged \rightarrow cannot directly compare
- Hard to summarize in a few plots... but I'm going to try...
- Use GENIE as a reference model



ν -A data-MC disagreement

arXiv: 1803.08848

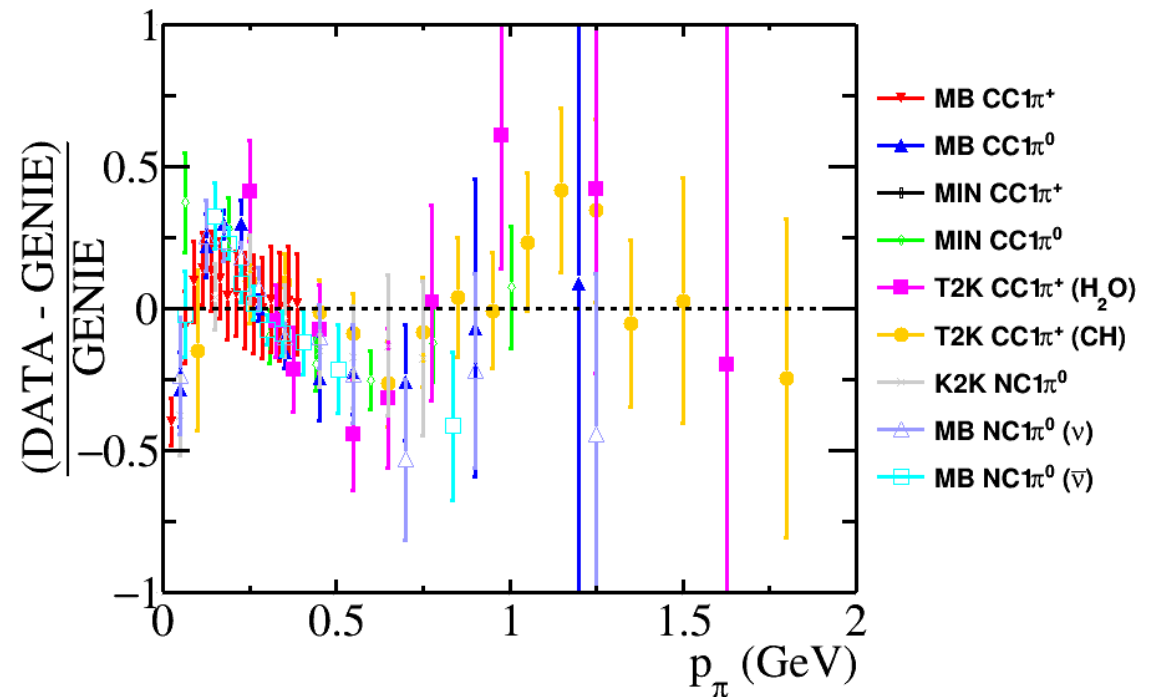
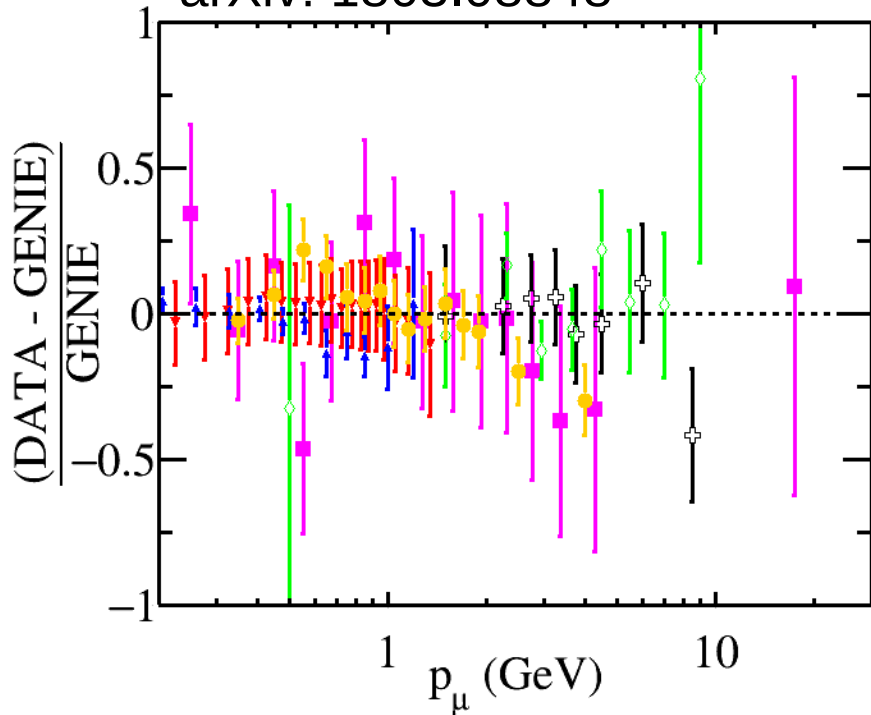

All available results given in terms of muon and pion momentum paint a confusing picture!

- p_μ *reasonably* well described
- p_π *very poorly* described



ν -A data-MC disagreement

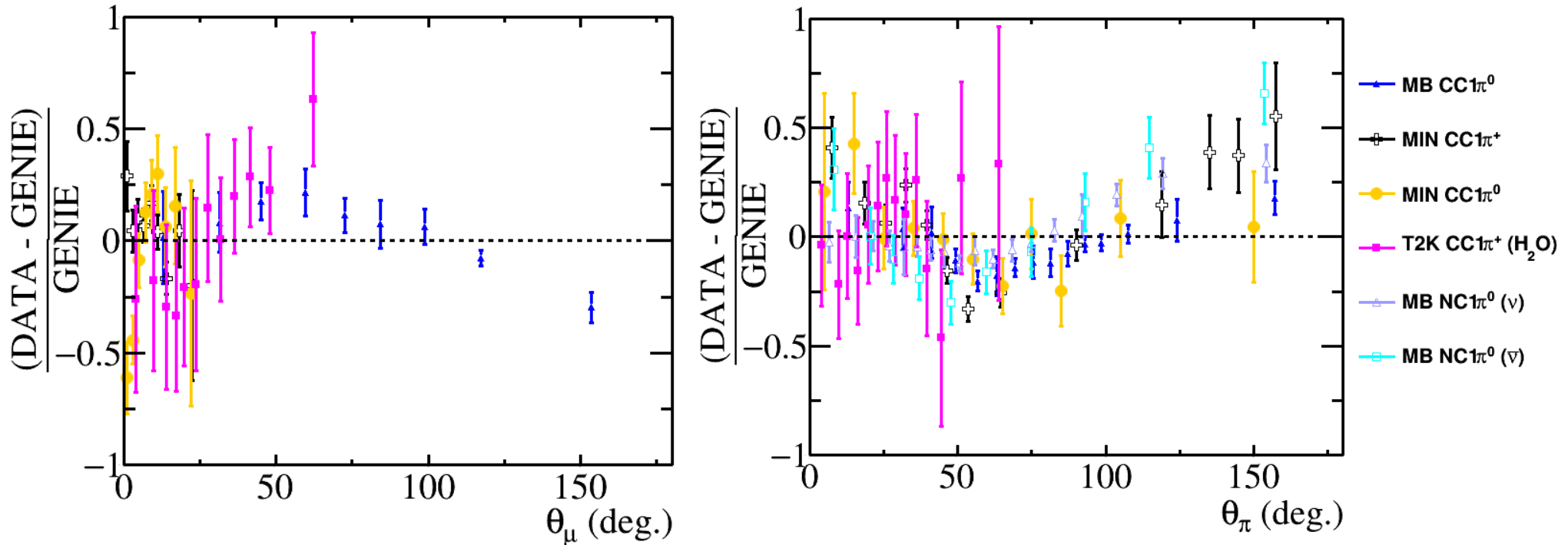

- Same for the available angular distributions
- Now, the muon is also not well described...
- **Current models are not predictive**

Nuclear target dependence

- Majority of data taken on hydrocarbon targets
- DUNE energy region will not be covered by other experiments
- Need to validate A-dependence of model, and ^{40}Ar in particular!
- Discrepancies in MINERvA data: C/CH, Fe/CH, Pb/CH

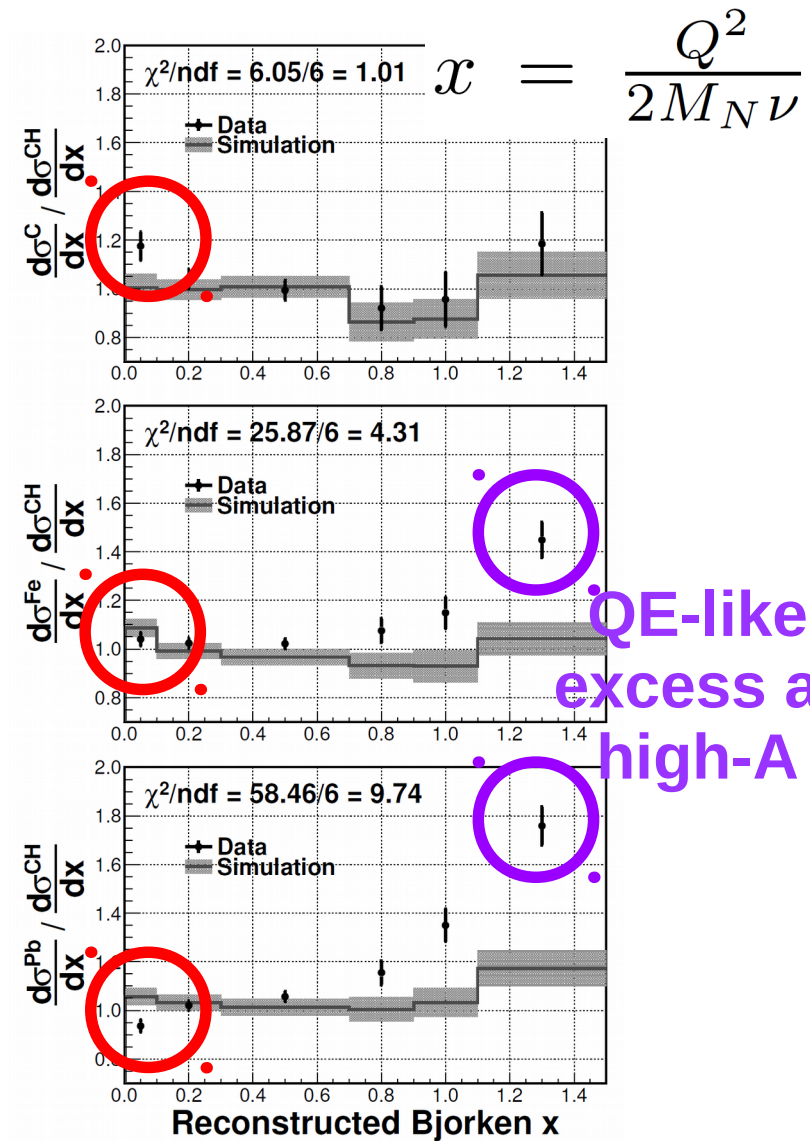

A-dependent low- x discrepancy

Outlook

- Cross sections are *hard*
- CC0 π in reasonable shape:
 - Range of increasingly stringent datasets available
 - But more theory work required to explain those datasets...
 - Overall, good news for T2K/HK!
- CC1 π and higher W interactions in less good shape:
 - Significantly less theoretical work than CC0 π
 - Challenging to measure, many datasets seem to disagree
 - A worry for NOvA and DUNE
- No prospect for comprehensive ^{40}Ar data before DUNE, A -dependence a problem

Backup

$\nu_e/\bar{\nu}_\mu$ cross sections

- $\nu_\mu/\bar{\nu}_\mu$ ND measurements used to constrain $\nu_e/\bar{\nu}_e$ FD prediction
- $\nu_e/\bar{\nu}_e$ appearance shape important for next generation osc. expts.
- Limited ν_e data, first ν_e/ν_μ from MINERvA

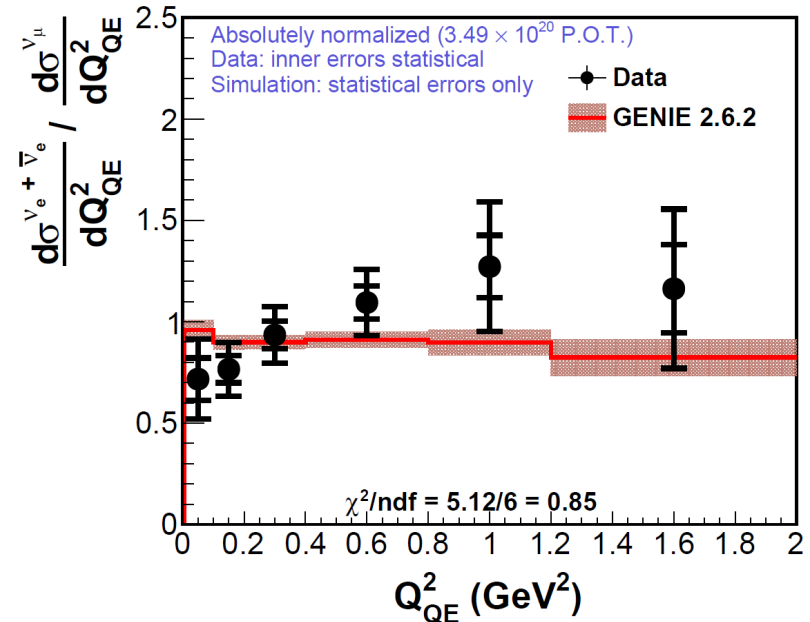
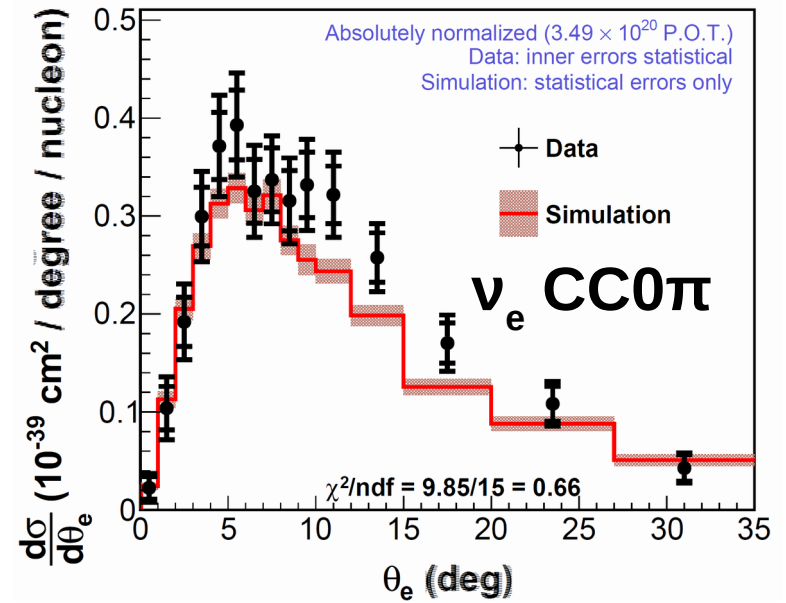

PRD91 (2015) 112010

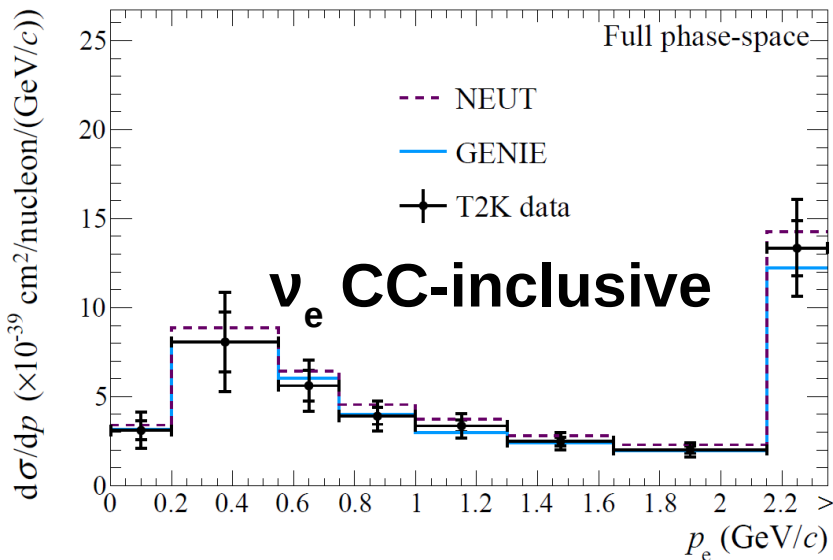

PRL116 (2016) 081802

$\bar{\nu}/\nu$ ratio

- CP-asymmetry depends on $\bar{\nu}/\nu$ cross section ratio
- Need ratio measurements or correlations between $\bar{\nu}$ and ν to reduce uncertainty
- CC-inclusive ratios from T2K and MINERvA, but ratios in exclusive channels missing

$$\mathcal{A}_{CP} = \frac{P(\nu_{\mu} \rightarrow \nu_e) - P(\bar{\nu}_{\mu} \rightarrow \bar{\nu}_e)}{P(\nu_{\mu} \rightarrow \nu_e) + P(\bar{\nu}_{\mu} \rightarrow \bar{\nu}_e)}$$

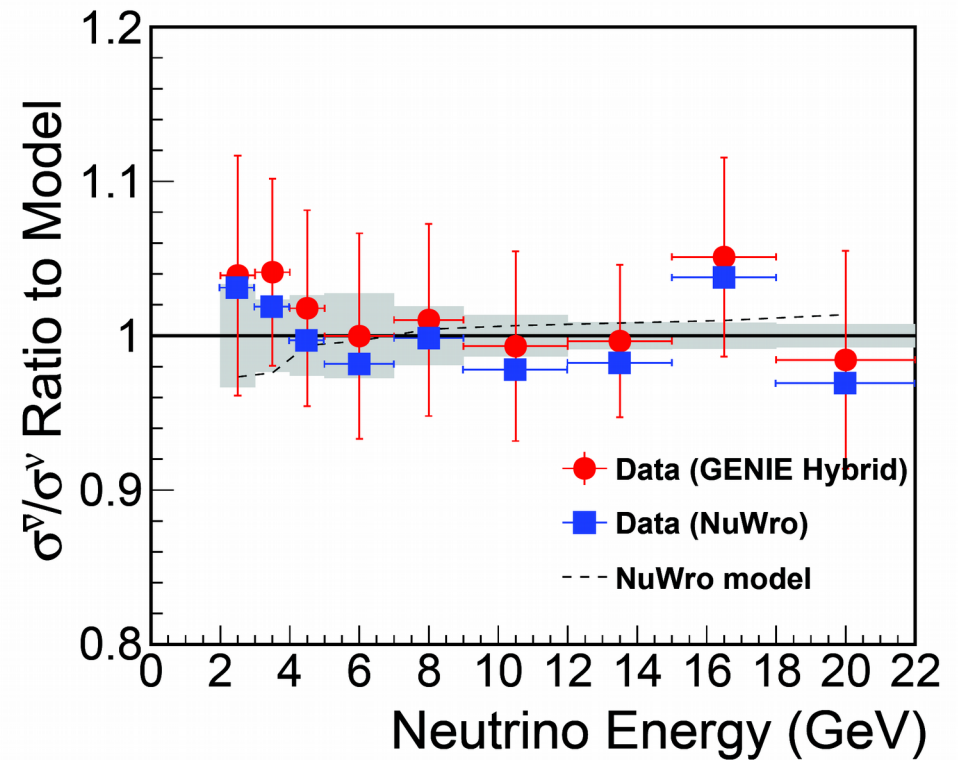

ν -A cross section data

- Can only measure for outgoing particle kinematics, as a function of **topology**, not **interaction** channel

$$\tilde{\sigma}_k(\vec{y}) = \sum_i \int_{E_{\min}}^{E_{\max}} \sigma_i(E_\nu, \vec{x}) \times \text{FSI}(\vec{x}, \vec{y}) dE_\nu$$

- Integrated over a broad neutrino flux
- Post-FSI, integrate out all degrees of freedom other than \vec{y} :
 - Direct theory comparisons to data are difficult
 - Require Monte Carlo generator to do integrals numerically



Cross section model dependence



Some unfolding methods introduce bias

The signal definition and background subtraction can be model dependent

$$\frac{d\sigma}{dx_i} = \frac{\sum_j \tilde{U}_{ij}^{-1} (N_j - B_j)}{\Phi_\nu T \Delta x_i \epsilon_i}$$

Choice of variables

Efficiency corrections couple to model in complex ways

Neutrino energy reconstruction (1)

- Use **leptonic** and **hadronic** information:

$$E_\nu = E_\mu + \sum E_{hadronic}$$

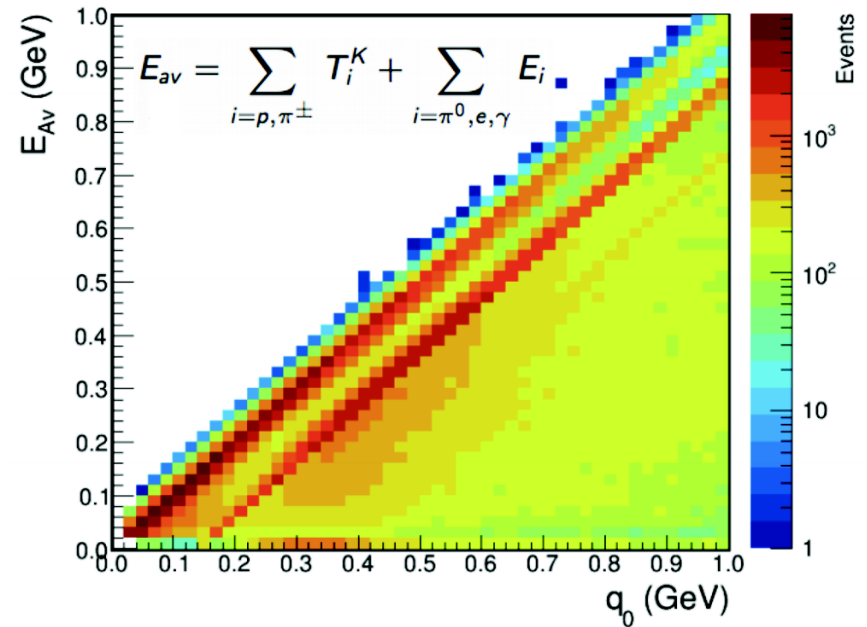
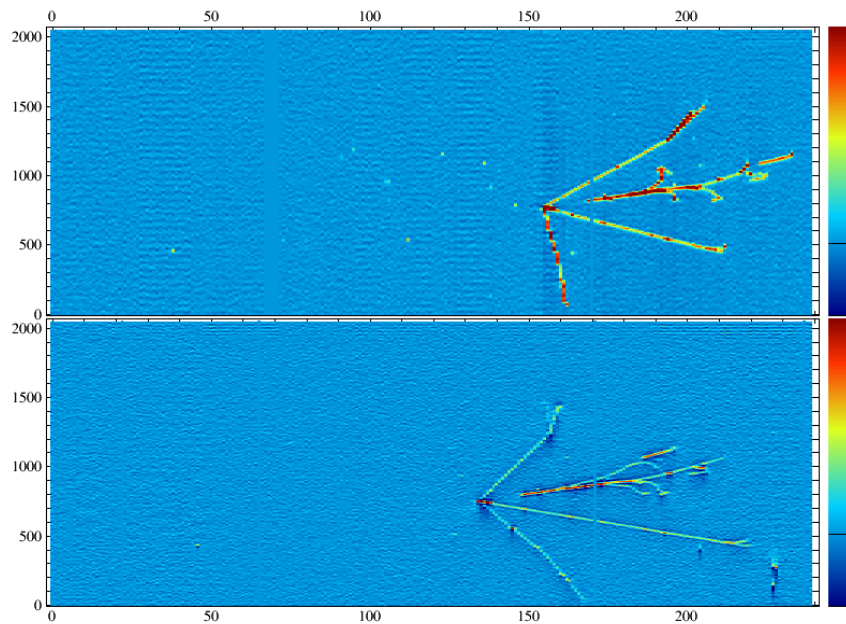

- Miss neutral particles
- Without track by track PID, miss particle masses
- Smearing from initial nuclear state

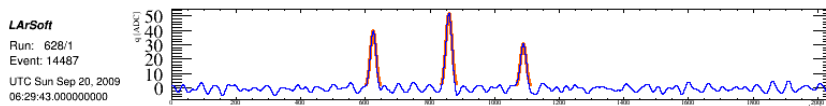

CC0π and E_ν reconstruction

E_ν from **leptonic** variables:

$$E_{\nu}^{QE} = \frac{m_p^2 - m_n'^2 - m_{\mu}^2 + 2m_n' E_{\mu}}{2(m_n' - E_{\mu} + p_{\mu} \cos \theta_{\mu})}$$

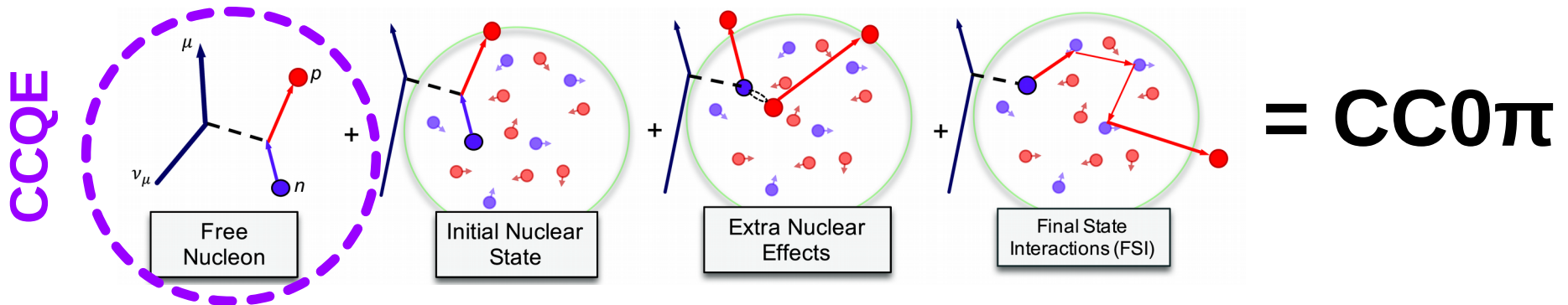
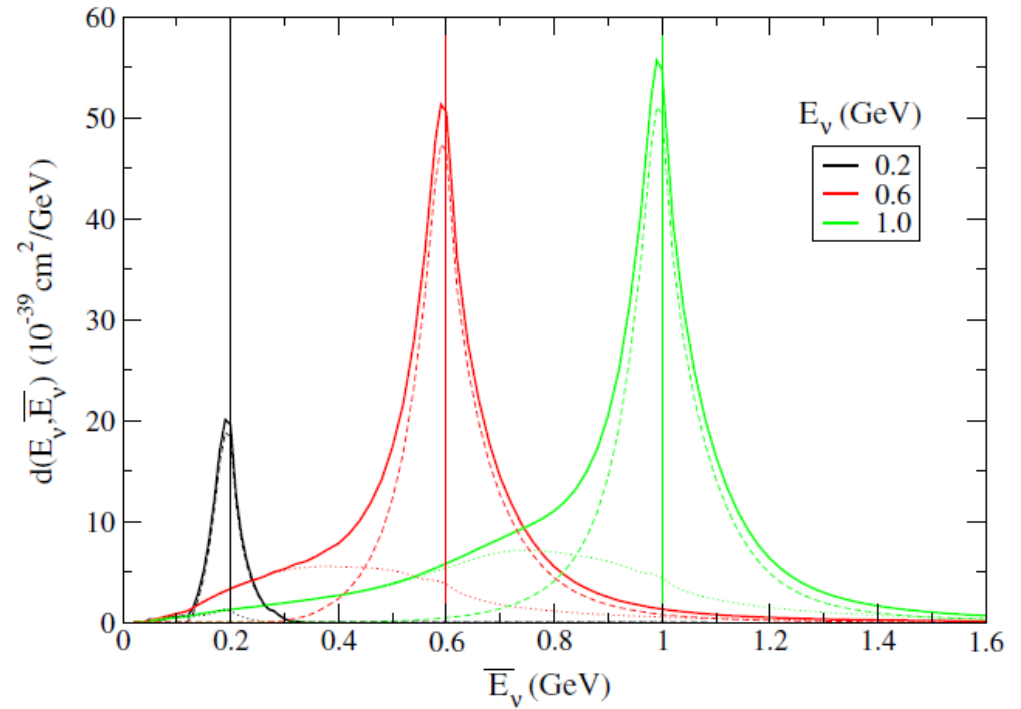
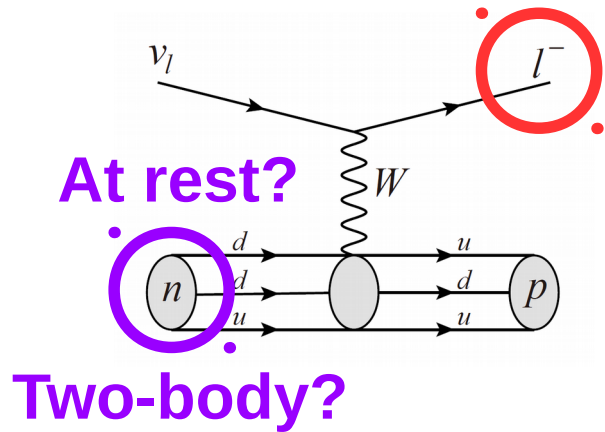

$$\text{CC0}\pi = 1p1h + 2p2h + 1\pi(+\text{abs}) + \dots$$

Final State Interactions

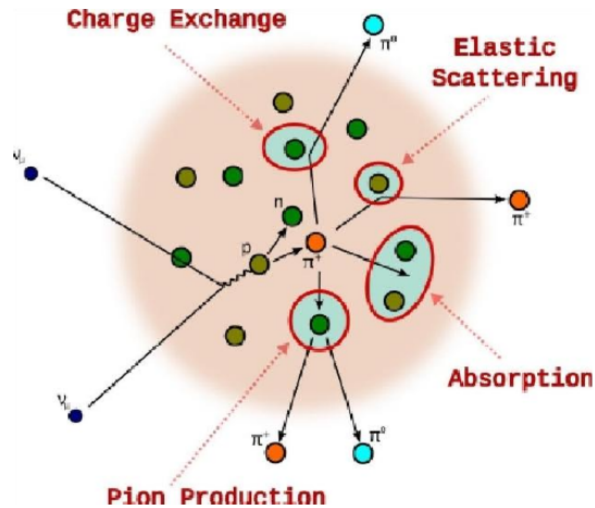

- Pions or nucleons can re-interact with the nuclear medium, or each other before leaving the nucleus.
- Changes outgoing particle content or kinematics in final state → **neutron multiplicities**

- Theory driven, with some constraints from π -A or N-A data
- But, always require a model to relate the data to *intra-nuclear* scattering

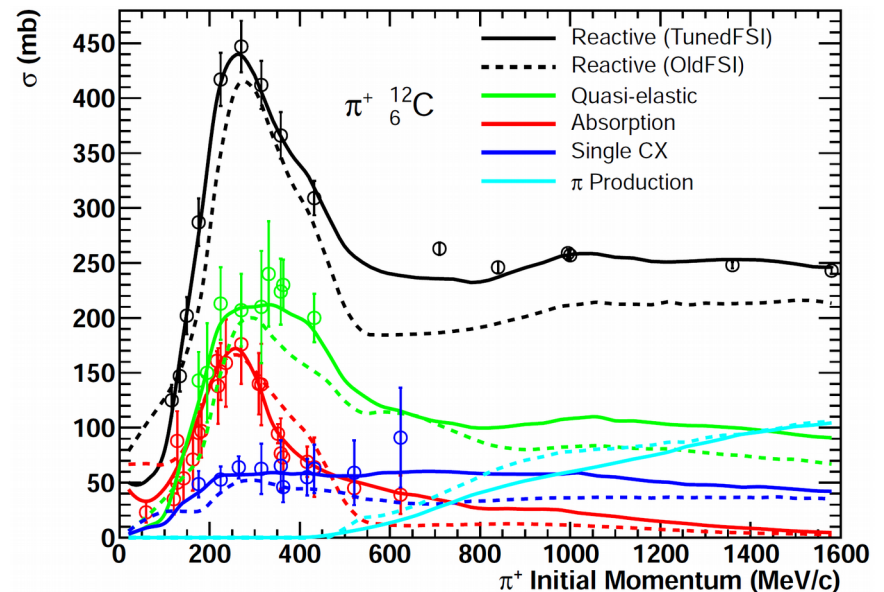

Cascade model

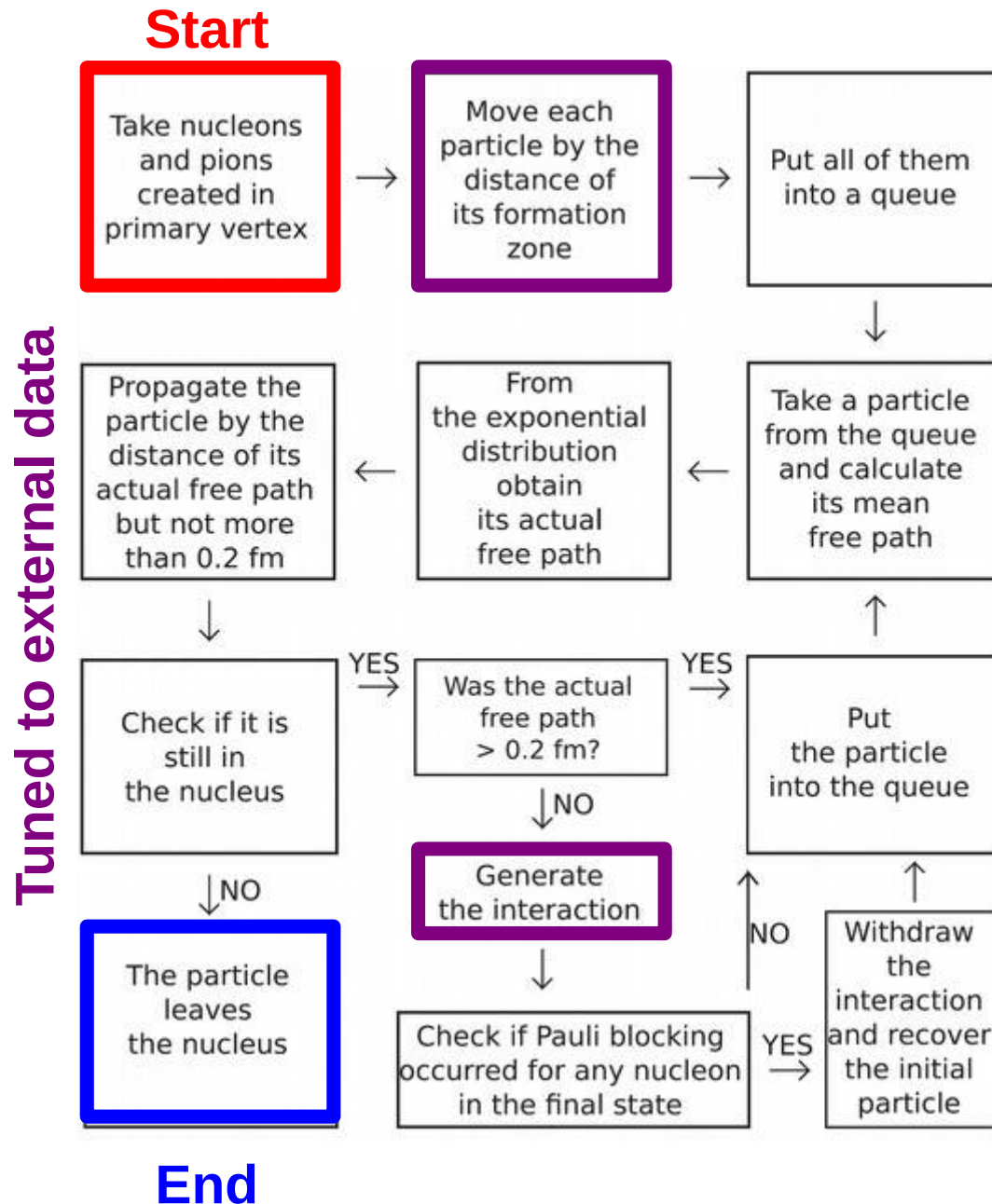

Neglect interactions between outgoing particles, propagate each individually (except for GiBUU).

Formation zones are motivated by data (high E, high Q^2). Interaction cross sections suppressed after production.

- NuWro: all modes
- GENIE & NEUT: DIS only
- Others: no formation zone

Re-interactions depend on local density of the nucleus.

2p2h

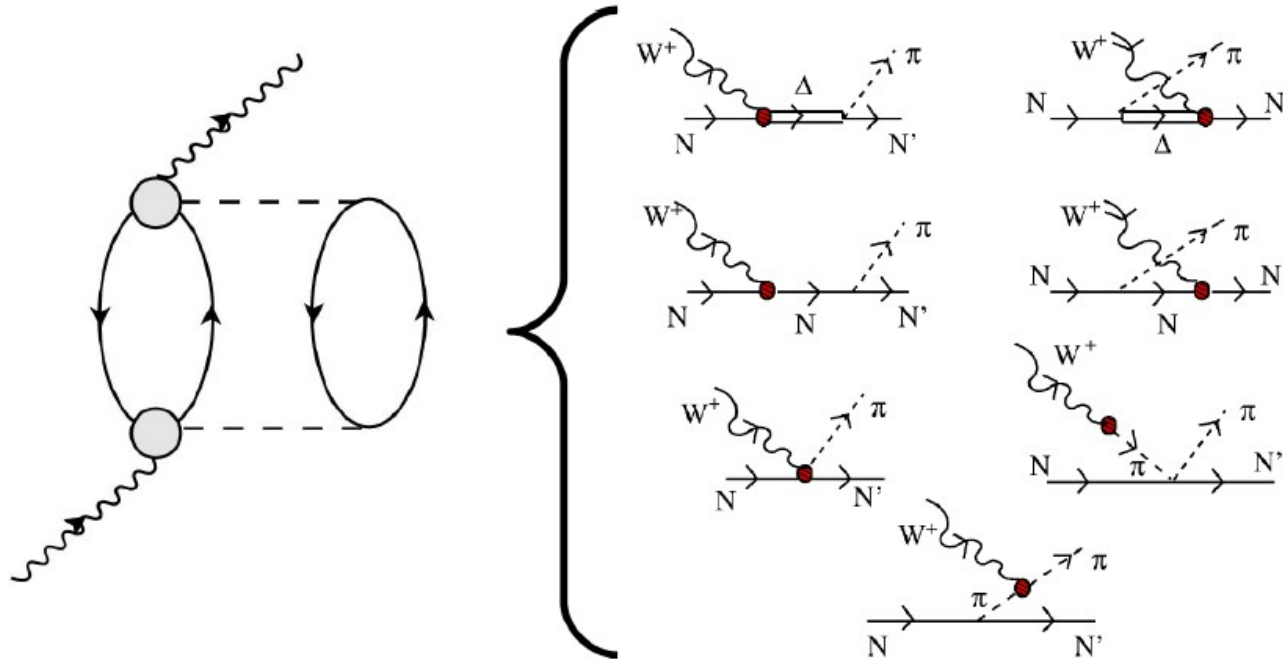

- Second order contributions to the cross section, where the probe interacts with two or more bound nucleons.
 - ~30% effect on total cross section
 - Now implemented in neutrino generators (although not perfect!).

Muon (anti)neutrino disappearance

Same probability
for ν_μ and $\bar{\nu}_\mu$

Weak dependence
on $\theta_{23} > 45^\circ$ or $< 45^\circ$

$$P(\bar{\nu}_\mu \rightarrow \bar{\nu}_\mu) = 1 - (\underbrace{\cos^4 \theta_{13} \sin^2 2\theta_{23}}_{\text{red}} + \underbrace{\sin^2 2\theta_{13} \sin^2 \theta_{23}}_{\text{green}}) \underbrace{\sin^2 \Phi_{32}}_{\text{blue}} + \dots$$

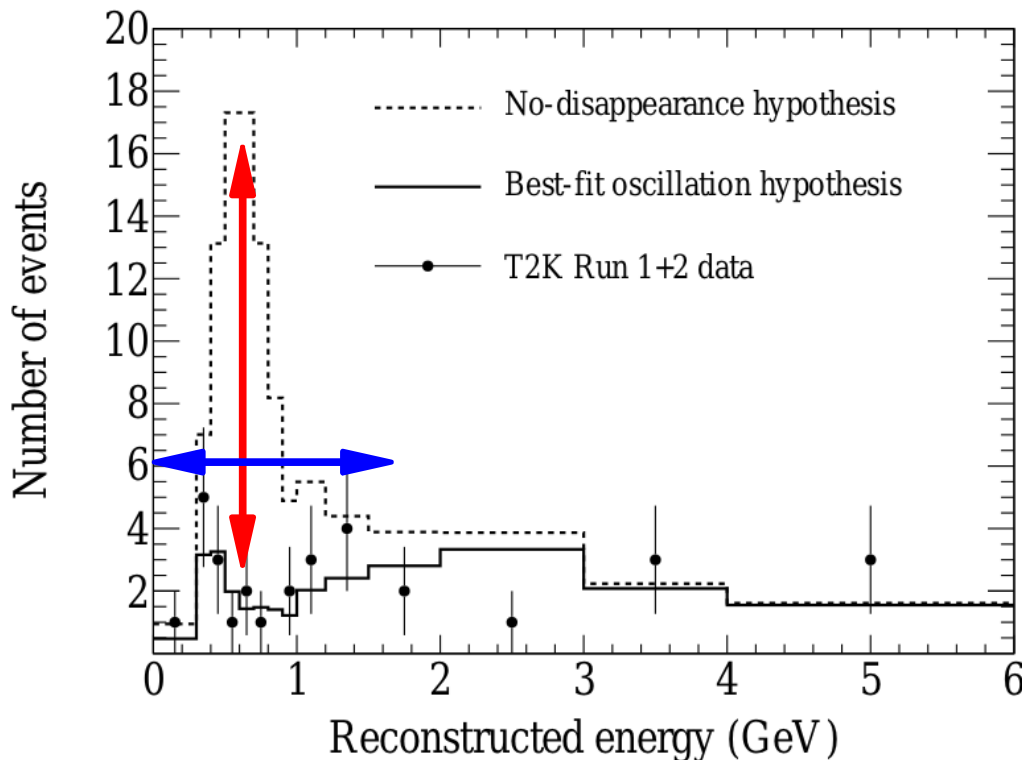

$$\Phi_{ji} = \frac{1.27 \Delta m_{ji}^2 L}{E_\nu}$$

Oscillation controlled by an
amplitude, and a **phase**

Electron (anti)neutrino appearance

$$P(\bar{\nu}_\mu \rightarrow \bar{\nu}_e) = \sin^2 \theta_{23} \sin^2 2\theta_{13} \sin^2 \Phi_{31}$$

Dependence
on $\pm\Delta m_{31}^2$

Sign change for ν_e and $\bar{\nu}_e$

$$- \sin \delta_{\text{CP}} \frac{\sin 2\theta_{12} \sin 2\theta_{23}}{2 \sin \theta_{13}} \sin^2 2\theta_{13} \sin \Phi_{21} \sin \Phi_{31} + \dots$$

$$\Phi_{ji} = \frac{1.27 \Delta m_{ji}^2 L}{E_\nu}$$

T2K flux, $L = 295$ km

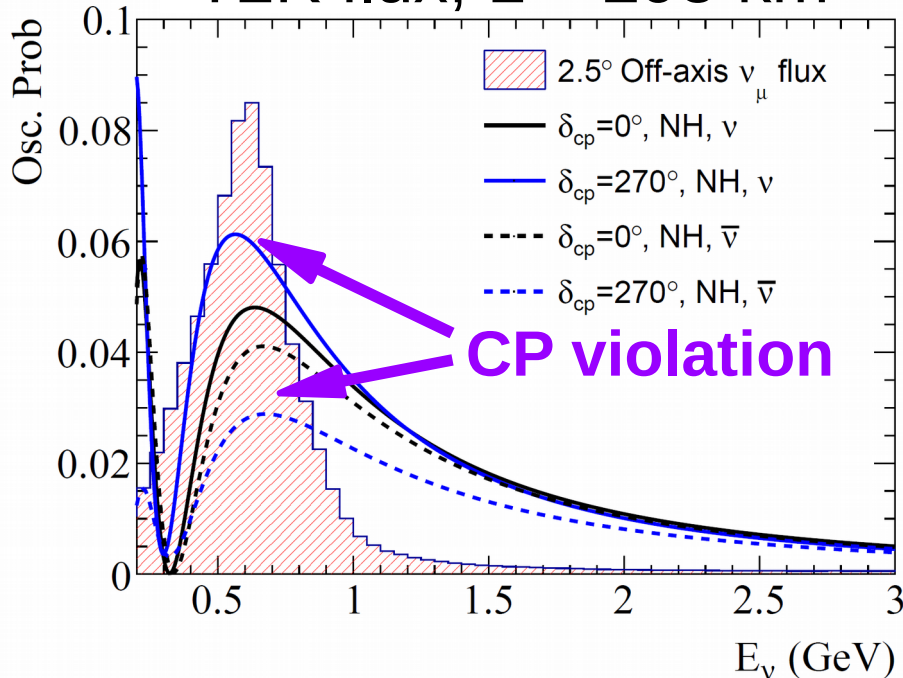

Complex relationship between parameters. Require high statistics and excellent E_ν resolution!

$$\frac{\delta E_\nu}{E_\nu} \lesssim 5\%$$